

**This electronic collection of documents is provided
for the convenience of the user
and is Not a Certified Document –**

**The documents contained herein were originally issued
and sealed by the individuals whose names and license
numbers appear on each page, on the dates appearing
with their signature on that page.**

**This file or an individual page
shall not be considered a certified document.**

NCDOT HATTERAS FERRY DOCK REPLACEMENT

STATE	STATE PROJECT REFERENCE NO.	SHEET NO.	TOTAL SHEETS
		1	26
STATE PROJ. NO.	F. A. PROJ. NO.	DESCRIPTION	
50801.1.2	5080111	PE	
50801.3.2	5080111	CON	

LOCATION:Hatteras Island, NC

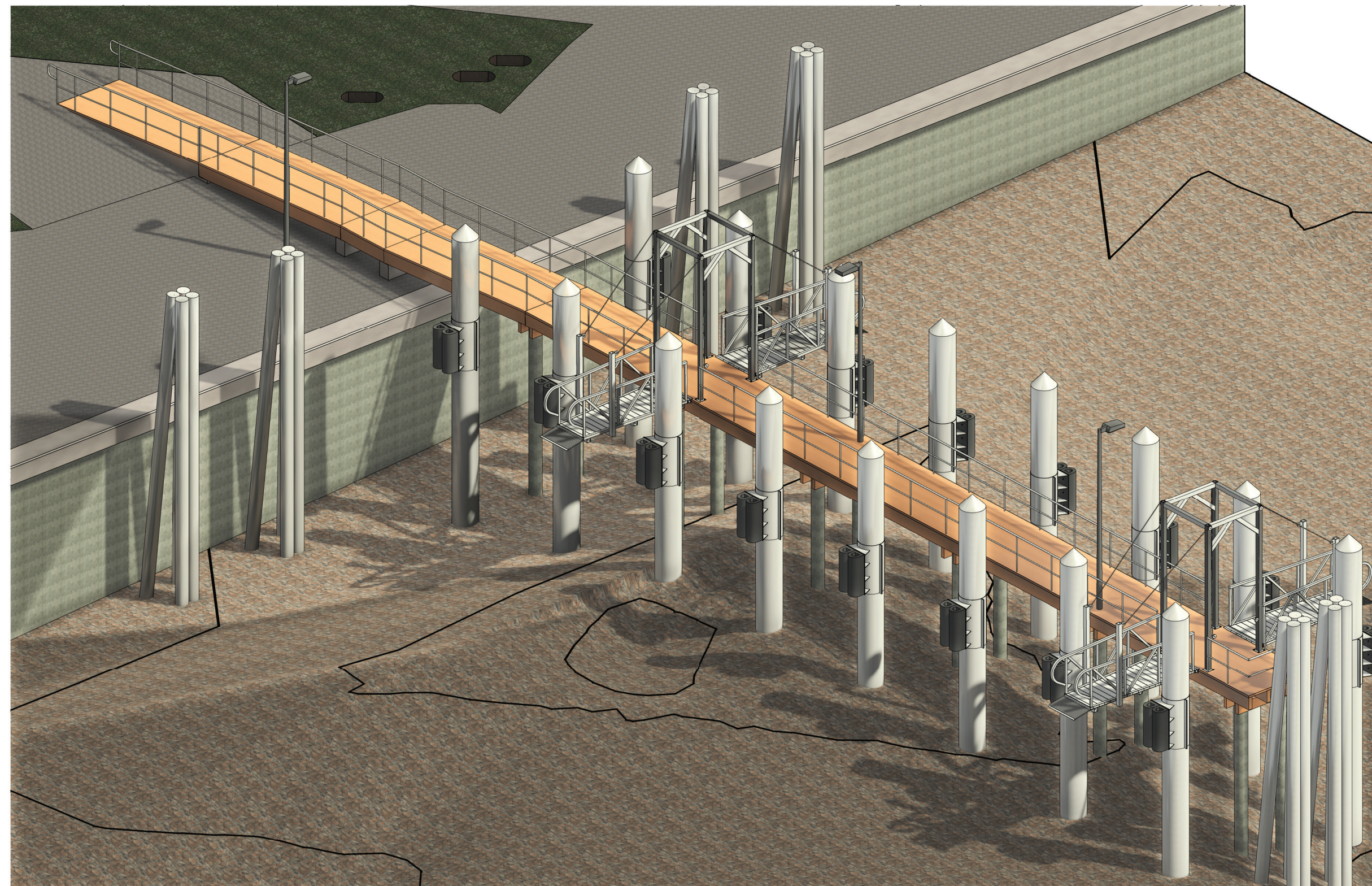

3D VIEW

NCDOT HATTERAS FERRY DOCK REPLACEMENT PROJECT

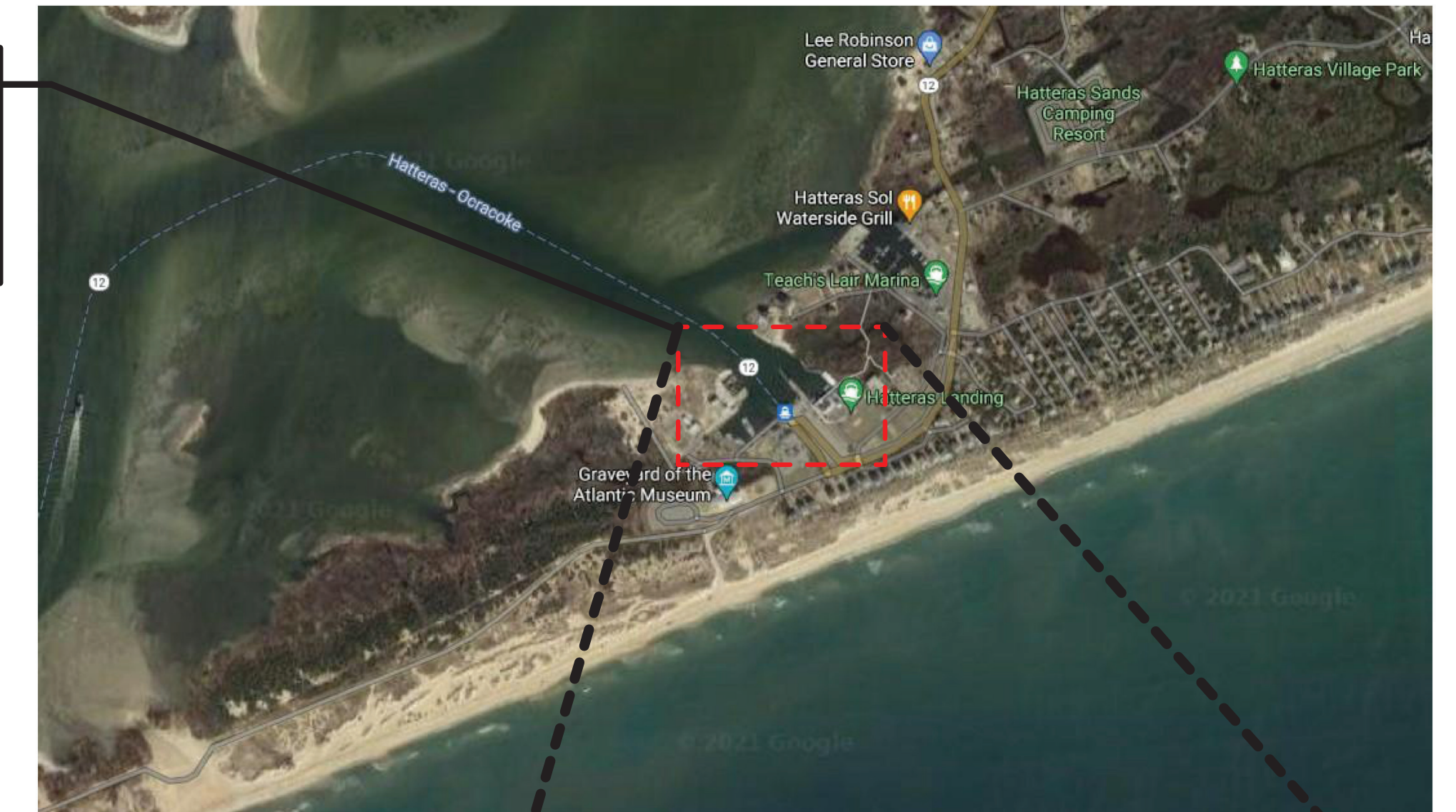

LOCATION MAP

NCDOT HATTERAS FERRY DOCK REPLACEMENT PROJECT



VICINITY MAP

MARINE DISCIPLINE		
1	G-001	COVER SHEET
2	G-002	MARINE GENERAL NOTES (1 OF 2)
3	G-003	MARINE GENERAL NOTES (2 OF 2)
4	D-101	EXISTING CONDITIONS AND DEMOLITION PLAN
5	D-102	NOT USED
6	D-103	NOT USED
7	M-101	MARINE OVERALL SITE PLAN
8	M-102	FOUNDATION AND PILE LAYOUT PLAN
9	M-103	PIER FRAMING PLAN
10	M-301	LONGITUDINAL SECTION & ELEVATION
11	M-302	TRANSVERSE SECTION
12	M-401	HOIST FRAME DETAILS
13	M-501	MISCELLANEOUS DETAILS (1 OF 5)
14	M-502	MISCELLANEOUS DETAILS (2 OF 5)
15	M-503	MISCELLANEOUS DETAILS (3 OF 5)
16	M-504	MISCELLANEOUS DETAILS (4 OF 5)
17	M-505	MISCELLANEOUS DETAILS (5 OF 5)

ELECTRICAL DISCIPLINE		
21	E-001	ELECTRICAL LEGEND AND NOTES 1
22	E-002	ELECTRICAL LEGEND AND NOTES 2
23	E-003	ELECTRICAL DIAGRAMS
24	E-004	ELECTRICAL SCHEDULES
25	E-100	ELECTRICAL SITE PLAN
26	E-900	ELECTRICAL LIGHTING DETAILS

CIVIL DISCIPLINE		
18	C-101	WATER SERVICE PLAN
19	C-102	WATER SERVICE DETAILS
20	C-103	EROSION CONTROL DETAILS

Digitally signed by Kristopher P Pagan-Cruz
Date: 2026.05.01 16:31:43-04'00'

SHEET 1 OF 26

TIP PROJECT: FF-0001A

CONTRACT: DA-00701

ANSI D (84"x22")

M M
MOTT MACDONALD
930 Main Campus Drive,
Suite 200
Raleigh, NC 27606
License No. F-0669
T +1 (919) 552 2253
F +1 (919) 552 2254
www.mottmacamericas.com

GRAPHIC SCALE

PROJECT ENGINEER
NORTH CAROLINA PROFESSIONAL SEAL
KRISTOPHER PHERNANDO PAGONCruz
044825

Designed By	JAVIER QUIROS	County	DARE COUNTY
Entered By	VICTOR PADILLA	Division	FERRY DIVISION
Project Engineer	KRISTOPHER PAGAN	Plan Date	1-14-26
Project Manager	ALLISON THORBURN		
Rev.	Date	Drawn	Description
			Ch'k'd
			App'd

NCDOT HATTERAS FERRY DOCK REPLACEMENT

G-001 COVER SHEET

GENERAL NOTES:

GENERAL CONSTRUCTION

- CONTRACTOR SHALL VERIFY ALL INFORMATION PROVIDED HEREIN WITH TECHNICAL SPECIFICATIONS AND OTHER DOCUMENTS AND SHALL NOTIFY ENGINEER, OF ANY CONFLICTS, IN WRITING, BEFORE WORK IS INITIATED.
- ALL DIMENSIONS AND DETAILS SHALL BE VERIFIED BY THE CONTRACTOR PRIOR TO FABRICATION AND CONSTRUCTION.
- CONTRACTOR SHALL COMPLY WITH THE REQUIREMENTS OF OSHA AND ALL OTHER APPLICABLE FEDERAL, STATE, AND LOCAL CODES, STANDARDS, REGULATIONS AND LAWS.
- THE CONTRACTOR SHALL MAINTAIN MARINE AND LAND TRAFFIC IN ACCORDANCE WITH AND SUBJECT TO ALL MARINE, COAST GUARD, AND NCDOT REQUIREMENTS DURING THE ENTIRETY OF PROJECT. THE CONTRACTOR SHALL SUBMIT A MAINTENANCE OF TRAFFIC PLAN TO ENGINEER, NCDOT FERRIES, AND COAST GUARD PRIOR TO CONSTRUCTION. THE CONTRACTOR SHALL INCLUDE IN THE BID ANY AND ALL COSTS ASSOCIATED WITH TRAFFIC MAINTENANCE INCLUDING BUT NOT LIMITED TO DAILY COMMUNICATIONS WITH COAST GUARD, ISSUANCE OF ADVISORIES OF LANE CLOSURES, AND MOVING IN AND OUT OF NAVIGATION CHANNELS AS REQUIRED TO ALLOW PASSAGE OF MARINE VESSELS.
- CONSTRUCTION ACTIVITIES SHALL BE PLANNED AND COORDINATED FREQUENTLY WITH NCDOT AND THE EOR TO ALLOW FERRY TERMINAL OPERATIONS TO CONTINUE DURING CONSTRUCTION. ANY CONSTRUCTION ACTIVITY THAT MAY PREVENT FERRY TERMINAL OPERATIONS FROM BEING PERFORMED SHALL BE NOTIFIED WITH AMPLE ADVANCE NOTICE TO NCDOT AND THE EOR FOR COORDINATION WITH THE FERRIES.
- THE CONTRACTOR SHALL PROTECT EXISTING FACILITIES, STRUCTURES, AND UTILITY LINES FROM ALL DAMAGE. THE CONTRACTOR SHALL ALSO PROTECT HIS WORK, ADJACENT PROPERTY, AND THE PUBLIC. THE CONTRACTOR IS SOLELY RESPONSIBLE FOR DAMAGE OR INJURY DUE TO HIS ACT OR NEGLIGENCE.
- THE CONTRACTOR SHALL ABIDE BY ALL APPLICABLE LOCAL ENVIRONMENTAL PROTECTION STANDARDS, PERMITTING LAWS, AND REGULATIONS.
- ALL APPLICABLE SAFETY REGULATIONS SHALL BE STRICTLY FOLLOWED. METHODS OF DEMOLITION, CONSTRUCTION, AND INSTALLATION OF STRUCTURAL MATERIAL ARE THE CONTRACTOR'S RESPONSIBILITY.
- LIMITED STAGING AREA WILL BE PROVIDED ON-SITE FOR CONTRACTOR'S USE. CONTRACTOR SHALL CONFIRM THE EXTENT AND LOCATION OF STAGING AREAS WITH NCDOT, PRIOR TO MOBILIZATION EXCEPT THAT WHICH SHALL BE PERFORMED OFF SHORE. SHALL BE CONDUCTED FROM BARGES, WORK BOATS, OR OTHER TEMPORARY PLATFORMS PROVIDED BY THE CONTRACTOR. CONTRACTOR SHALL RESPECT THE LIMITATIONS OF THE PROJECT SITE FOR STORING MATERIAL. CONTRACTOR SHALL COORDINATE WITH A WAY AS TO LIMIT THE NEED FOR STORED MATERIALS OR SHALL BE RESPONSIBLE FOR ALL ARRANGEMENTS AND COSTS FOR OBTAINING LAYDOWN AREA OR BARGES AS MAY BE REQUIRED.
- UTILITIES SHALL BE FIELD VERIFIED BY THE CONTRACTOR BEFORE DISTURBING ACTIVITIES. ANY UTILITY LINES LOCATED IN THE PROJECT AREA SHALL BE PROTECTED UNLESS SPECIFICALLY CALLED OUT TO BE DEMOLISHED.
- CONTRACTOR IS RESPONSIBLE TO REVIEW SITE CONDITIONS TO DEVELOP AN APPROPRIATE WORK PLAN FOR MOBILIZING AND CONDUCTING WORK AT THE SITE.
- CONTRACTOR SHALL VERIFY LAYOUT AND DIMENSIONS OF THE EXISTING PIERS PRIOR TO COMMENCING THE CONSTRUCTION. CARE MUST BE TAKEN SO AS TO NOT DAMAGE THE EXISTING PIERS AND OTHER STRUCTURES, FROM CONSTRUCTION LOADING, OR OTHERWISE. IF ANY DAMAGE IS OBSERVED ON THE EXISTING STRUCTURES DURING THE EXECUTION OF CONSTRUCTION WORK, ALL WORK AT SUCH LOCATION SHALL CEASE AND THE NCDOT SHALL BE CONTACTED TO REVIEW SUCH DAMAGES PRIOR TO WORK RESUMPTION.
- CONTRACTOR IS RESPONSIBLE FOR REPAIRING ALL DAMAGE TO EXISTING STRUCTURES THAT RESULT FROM CONSTRUCTION ACTIVITIES AT NO COST TO THE COUNTY AND STATE.

SUBMITTALS

- CONTRACTOR SHALL PROVIDE TO THE ENGINEER ALL SUBMITTALS (SHOP DRAWINGS, SAMPLES, MATERIAL CERTIFICATIONS, ETC) REQUIRED BY THE SPECIAL PROVISION SPECIFICATIONS FOR REVIEW PRIOR TO PURCHASE OR FABRICATION.

ENVIRONMENTAL PERMITS

- CONTRACTOR SHALL IMPLEMENT AND ABIDE BY ALL REGULATORY ENVIRONMENTAL REQUIREMENTS AS SPECIFIED IN THE ENVIRONMENTAL PERMITS SECURED BY NCDOT FOR THE PROJECT. IT SHALL BE THE CONTRACTOR'S SOLE RESPONSIBILITY TO COMPLY WITH ALL REGULATORY PERMIT REQUIREMENTS.
- CONTRACTOR SHALL ENSURE THAT TEMPORARY MEASURES AND REGULATORY MITIGATION REQUIREMENTS ARE IMPLEMENTED PRIOR TO INITIATING ANY CONSTRUCTION.

CONSTRUCTION LOADS

- CONTRACTOR IS RESPONSIBLE FOR ADEQUATE SHORING, BRACING, AND GUYING OF ALL COMPONENTS AS REQUIRED FOR SAFETY AND STRUCTURAL INTEGRITY THROUGHOUT CONSTRUCTION IN ACCORDANCE WITH SOUND PRACTICE.

CODES AND STANDARDS

- ALL METHODS AND MATERIALS SHALL CONFORM TO LOCAL BUILDING CODES AS AMENDED AND ADOPTED BY THE LOCAL COUNTY AND STATE AUTHORITIES.
- REFERENCE TO ASTM AND OTHER STANDARDS SHALL MEAN THE LATEST EDITION IN EFFECT ON THE BID DATE, UNLESS NOTED OTHERWISE IN THESE DOCUMENTS.
- AMERICANS WITH DISABILITIES ACT, ADA STANDARDS FOR ACCESSIBLE DESIGN, 2010
- AMERICAN SOCIETY OF CIVIL ENGINEERS, ASCE /SEI 7-16, "MINIMUM DESIGN LOADS FOR BUILDINGS AND OTHER STRUCTURES" ALL WORK SHALL CONFORM TO THE NCDOT STANDARD SPECIFICATIONS FOR ROAD AND STRUCTURES.

WATER LEVELS

WATER LEVELS DEFINED IN THE CONSTRUCTION DRAWINGS ARE FOR REFERENCE ONLY AND DO NOT INDICATE CONDITIONS DURING CONSTRUCTION. WATER LEVELS LISTED BELOW ARE REFERENCED TO NAVD88 DATUM AND WERE SOURCED FROM NOAA'S TIDE STATION 8654467, USCG HATTERAS, NC.

DATUM:	NAVD88
MEAN HIGHER HIGH WATER (MHHW)	+0.25'
MEAN TIDE LEVEL	+0.53'
MEAN LOWER LOW WATER (MLLW)	-0.39'

SURVEY INFORMATION:

- TOPOGRAPHIC AND BATHYMETRIC SURVEY WAS PROVIDED BY NCDOT, FILE NAME: Hatteras Passenger_LS_SSG_210628_dtl.dgn
- THE ELEVATIONS SHOWN ON THIS MAP ARE ACCURATE FOR THE DATE OF THAT SURVEY ONLY AND SHOULD NOT BE DEPENDED ON FOR ACCURACY AFTER THE DATE.

GEOTECHNICAL:

- GEOTECHNICAL RECOMMENDATIONS WERE DEVELOPED BASED ON THE STRUCTURE SUBSURFACE INVESTIGATION CONDUCTED BY CATLIN ENGINEERS AND SCIENTISTS AND DATED SEPTEMBER 2017 AND THE TECHNICAL MEMORANDUM PREPARED BY THE EASTERN REGIONAL OFFICE GEOTECHNICAL ENGINEERING UNIT DATED FEBRUARY 13, 2018.

DESIGN CRITERIA:

- DEAD LOAD CONSISTS OF THE SELF-WEIGHT OF THE STRUCTURE AND ALL PERMANENT ATTACHMENTS, INCLUDING MARINA ACCESSORIES (CLEATS, DOCK BOXES, LIGHTS, ETC.), UTILITIES (POTABLE WATER, FIREWATER, AND ELECTRIC/COMMUNICATIONS) AND FENDERING SYSTEMS.

MATERIAL WEIGHTS	
MATERIAL	UNIT WEIGHT
SELF-WEIGHT OF NORMAL WEIGHT CONCRETE:	150 LB/FT3
SELF-WEIGHT OF STRUCTURAL STEEL:	490 LB/FT3
TIMBER (TREATED):	60 LB/FT3
ALUMINUM ALLOYS:	175 LB/FT3
DD300 FENDERS:	60 LB/LF
COMPOSITE WOOD DECK:	28 LB/FT3

FIXED LANDING AREAS (LIVE LOAD):

CONCENTRATED:	650 LBS
UNIFORM:	100 PSF

BOARDING RAMP/ GANGWAY (LIVE LOAD):

UNIFORM:	50 PSF
DEFLECTION:	MAXIMUM L/240 (DEAD + LIVE)

FERRY DOCK OPERATION PARTICULARS:

DESIGN VESSEL:

VESSEL TYPE:	FERRY
CAPACITY:	125 PASSENGERS
LOA:	92 FEET
BEAM:	27 FEET
IMPACT SPEED:	0.6 KNOTS
FREEBOARD (LADEN):	7.0 FEET
FREEBOARD (LIGHT):	7.5 FEET
MIN. DRAFT:	4.0 FEET
MAX. DRAFT:	4.5 FEET

DESIGN COASTAL CONDITIONS:

THE FOLLOWING COASTAL CONDITIONALS HAVE BEEN USED TO DETERMINE THE WAVE LOADS USED IN THE DESIGN OF THE FIXED DOCK AND FENDER PILES. DESIGN STORM EVENT FOR VACANT CONDITION - NO VESSEL MOORED

WIND SPEED:	85 KNOTS (98 MPH)
SIGNIFICANT WAVE HEIGHT:	4.32 FEET
CURRENT:	<2.0 KNOTS
WATER SURFACE ELEVATION:	3.1 FEET (NAVD88)
TP	2.7 SEC

DESIGN STORM EVENT FOR OPERATIONAL LIMITS - MOORING (5-YR TROPICAL STORM EVENT)

WIND SPEED:	35 KNOTS (40 MPH)
SIGNIFICANT WAVE HEIGHT:	2.15 FEET
CURRENT:	<2.0 KNOTS
TP:	4.0 SEC

THE FOLLOWING PARAMETERS WERE USED IN THE DESIGN OF THE FENDER SYSTEM. BERTHING ANALYSIS AND DESIGN PARAMETERS:

MAXIMUM BERTHING VELOCITY:	1 FT/S
MAXIMUM BERTHING ANGLE:	10 DEGREES
DISPLACEMENT ESTIMATED:	201.9 TONNES
ECCENTRICITY FACTOR (CE) ¼ POINT:	0.40
VIRTUAL MASS FACTOR:	1.50
NORMAL BERTHING HULL PRESSURE:	<4.2 KSF

WIND LOADS (ON STRUCTURE):

- WIND LOADS ARE IN ACCORDANCE WITH ASCE 7-16.
- BASIC WIND SPEED IS 141 MPH FOR DESIGN CATEGORY II.

MATERIALS:

STRUCTURAL AND MISCELLANEOUS STEEL:

- ALL MISCELLANEOUS STEEL SHAPES AND PLATES SHALL BE HOT-DIP GALVANIZED UNLESS OTHERWISE NOTED.
- ALL FASTENERS AND CONNECTORS INCLUDING BOLTS, NUTS, WASHERS, LAG SCREWS, SCREWS PLATES, AND ANGLES SHALL BE HOT-DIP GALVANIZED UNLESS OTHERWISE NOTED.
- ALL MISCELLANEOUS STEEL THAT IS NOT STAINLESS STEEL OR HOT DIP GALVANIZED SHALL RECEIVE A PROTECTIVE PAINT COATING EQUAL TO THE COATING SPECIFIED FOR THE STEEL FENDER PILES.

ALUMINUM BOARDING RAMPS:

- THE ENGINEER OF RECORD DELEGATES THE RESPONSIBILITY FOR THE DESIGN OF THE ALUMINUM BOARDING RAMPS TO A SPECIALTY ENGINEER LICENSED IN THE STATE OF NORTH CAROLINA. ALL BOARDING RAMPS SUBMITTALS INCLUDING BUT NOT LIMITED TO DRAWINGS AND CALCULATIONS SHALL BE SUBMITTED TO THE ENGINEER OF RECORD FOR REVIEW. ALL SHOP DRAWING SUBMITTALS SHALL BE SIGNED, SEALED AND DATED BY THE SPECIALTY ENGINEER.
- ALUMINUM BOARDING RAMPS SHALL BE PREFABRICATED FROM ALUMINUM MEETING THE FOLLOWING REQUIREMENTS:
 - THE DESIGN SHALL CONFORM TO IBC CODE AND ALUMINUM DESIGN MANUAL REQUIREMENTS AND SPECIAL PROVISIONS.
 - THE ALUMINUM BOARDING RAMP FABRICATION SHALL CONFORM TO ALUMINUM ALLOY 6061-T6 OR 6063-T6 AND WELDING SHALL BE IN ACCORDANCE WITH AWS D1.2.
 - GRATING, HANDRAILS, AND TRANSITION PLATES SHALL BE ADA COMPLIANT.
 - LOCATIONS, LENGTHS, AND CLEARANCES INDICATED IN THE DRAWINGS ARE APPROXIMATE.
 - FINAL BOARDING RAMP LENGTHS, CLEARANCES, AND CONNECTIONS SHALL BE FIELD VERIFIED BY THE CONTRACTOR PRIOR TO THE DESIGN AND FABRICATION.

WOOD FIXED DOCK:

- ALL LUMBER SHALL BE MANUFACTURED AND GRADED IN ACCORDANCE WITH THE CURRENT EDITION OF THE STANDARD GRADING RULES FOR SOUTHERN PINE TIMBER, OF THE SOUTHERN PINE INSPECTION BUREAU. THE REQUIREMENTS OF NO. 1 DENSE SHALL APPLY. ALL LUMBER AND TIMBER SHALL CONFORM TO GRADE NO. 1 DENSE OR SELECT STRUCTURAL (SEL STR.) AS APPLICABLE AND SHALL BEAR THE GRADE MARK OF AN ALSC-ACCREDITED AGENCY.
- TIMBER AND LUMBER SHALL BE SOUTHERN PINE AND SHALL BE IN ACCORDANCE WITH THE FOLLOWING SPECIFICATIONS:
 - PILES - ROUND TIMBER WITH A MINIMUM TIP CIRCUMFERENCE OF 38" (12" DIAMETER) IN ACCORDANCE WITH ASTM D25. PILES SHALL BE SOUTHERN PINE, GRADED IN ACCORDANCE WITH SPIB RULES AS NO.1 DENSE OR SEL STR., AND KILN-DRIED TO MC-19 OR LESS. LENGTH SHALL BE IN ACCORDANCE WITH THE PILE SCHEDULE.
 - DIAGONAL BRACING - MARINE GRADE NO. 1. BRACING SHALL BE SOUTHERN PINE, GRADED IN ACCORDANCE WITH SPIB RULES AND KILN-DRIED TO MC19 OR LESS.
 - SPLIT PILE CAPS, JOISTS AND HAND RAILS - NO. 1 DENSE SOUTHERN PINE. MATERIAL SHALL BE GRADED IN ACCORDANCE WITH SPIB RULES AND KILN-DRIED TO MC-19 OR LESS.
 - DECKING - 2"x6" COMPOSITE WOOD DECK EQUAL OR SIMILAR TO WEARDECK COMPOSITE DECKING.

TIMBER TREATMENT:

- ALL LUMBER AND TIMBER MATERIALS SHALL BE PRESSURE TREATED IN ACCORDANCE WITH AASHTO M 133, AND AMERICAN WOOD PROTECTION ASSOCIATION (AWPA) STANDARD U1 AND THE FOLLOWING USE CATEGORIES DESIGNATIONS:
 - PILES - USE CATEGORY 5B, PRESSURE TREATED USING CHROMATE COPPER ARSENATE (CCA) WITH A MINIMUM RETENTION REQUIREMENT OF 2.5 POUNDS PER CUBIC FOOT.
 - DIAGONAL BRACING - USE CATEGORY 5B, PRESSURE TREATED USING CHROMATE COPPER ARSENATE (CCA) WITH A MINIMUM RETENTION REQUIREMENT OF 2.5 POUNDS PER CUBIC FOOT.
 - SPLIT PILE CAPS AND JOISTS - USE CATEGORY 4B, PRESSURE TREATED USING CHROMATE COPPER ARSENATE (CCA) WITH A MINIMUM RETENTION REQUIREMENT OF 0.60 POUNDS PER CUBIC FEET.
- INSPECTION OF PRESERVATIVE-TREATED MATERIAL SHALL BE PERFORMED IN ACCORDANCE WITH AWPA M2 BY AN INSPECTION AGENCY LISTED ON THE DEPARTMENT'S PRE-APPROVED PRODUCER/SUPPLIER LIST. EACH PIECE SHALL BEAR THE QUALITY MARK OF AN ALSC-ACCREDITED AGENCY IN ACCORDANCE WITH AWPA M6.
- PROVIDE TYPE 4 CERTIFIED TEST REPORTS AND TYPE 6 SUPPLIER CERTIFICATIONS IN ACCORDANCE WITH ARTICLE 106-3, INCLUDING CHAIN-OF-CUSTODY DOCUMENTATION.

STEEL PILES

- STEEL PILES SHALL CONFORM TO ASTM A252 GRADE 3, WITH MINIMUM YIELD STRENGTH OF 50 KSI.
- PIPE PILING SPLICES SHALL BE FABRICATED WITH FULL PENETRATION WELDS ACCORDING TO DETAIL ON DRAWINGS.
- PILES SHALL MEET THE MARINE COATING REQUIREMENTS LISTED IN THE SPECIAL PROVISIONS.
- PILES SHALL BE COATED FROM CUTOFF ELEVATION TO -17'-0" MLLW.

TREATED TIMBER PILES

- ALL TIMBER PILES SHALL BE IN ACCORDANCE WITH NCDOT STANDARD SPECIFICATIONS FOR ROADS AND BRIDGES SECTION 1084 AS MODIFIED BY SP10 RB2 PILES.
- TIMBER PILES SHALL CONFORM TO ASTM D25. TIMBER PILES SHALL BE SOUTHERN PINE, GRADED IN ACCORDANCE WITH SPIB RULES AS NO.1 DENSE OR SEL STR. AND SHALL MEET SUMMERWOOD REQUIREMENTS OF SP10 RB2.
- THE TREATING OF SOUTHERN YELLOW PINE SHALL BE IN CONFORMANCE WITH NCDOT STANDARD SPECIFICATIONS ROADS AND BRIDGES SECTION 1082 STRUCTURAL TIMBER AND LUMBER AND SECTION 1084 PILES.
- TIMBER SHALL BE NO.1 DENSE OR SELECT STRUCTURAL AND SHALL BEAR THE MARK OF AN ALSC-ACCREDITED AGENCY.

FENDERS

- FENDERS SHALL BE EXTRUSION TYPE DD300 SECTION FENDERS BY TRELLEBORG OR APPROVED EQUAL, WITH A MINIMUM ENERGY ABSORPTION CAPACITY OF 12.9 kNm/m AND MAXIMUM REACTION OF 230 kNm/m. COMPLETE WITH ANCHORING MECHANISM TO INSTALL ON THE FENDER PILES AS SHOWN ON THE DRAWINGS. CONTRACTOR SHALL SUBMIT MANUFACTURER'S PRODUCT LITERATURES AND SHOP DRAWINGS TO NCDOT FOR REVIEW AND APPROVAL.

MOORING

- CLEATS: ALL CLEATS SHALL BE CONNECTED TO THE FENDER PILES TO MOOR THE VESSEL WITHIN OPERATIONAL WIND SPEED LIMITS AS SPECIFIED IN THE FERRY DOCK OPERATIONS PARTICULARS.

PILE INSTALLATION

- PILES SHALL BE INSTALLED TO ACHIEVE THE SPECIFIED PILE TIP ELEVATIONS. CONTRACTOR IS RESPONSIBLE FOR THE SELECTION OF THE APPROPRIATE PILE HAMMER OR DRILL TO ACHIEVE THE PILE TIP ELEVATION. CONTRACTOR SHALL BE FAMILIAR WITH THE PROJECT SITE CONDITIONS AND SHALL REVIEW THE SUPPLIED GEOTECHNICAL DATA.
- PILES HITTING OBSTACLES, MISALIGNED PILES AND PILES THAT HAVE NOT ACHIEVED MINIMUM PENETRATION SHALL BE PULLED BY THE CONTRACTOR AND REINSTALLED AT NO ADDITIONAL COST.
- THE CONTRACTOR SHALL BE RESPONSIBLE OF MONITORING ADJACENT STRUCTURES FOR VIBRATION, MOVEMENT, OR DAMAGES DURING THE PILE INSTALLATION OPERATIONS. IF MOVEMENT OR DAMAGES TO THE STRUCTURES ARE DETECTED, THE PILE INSTALLATION SHALL BE HALTED IMMEDIATELY. PHOTOS OF THE STRUCTURES SHALL BE TAKEN BEFORE AND AFTER THE PILE DRIVING OPERATION BY CONTRACTOR.

CONCRETE

- CONCRETE SHALL BE CLASS AA WITH A MINIMUM 28-DAY COMPRESSIVE STRENGTH OF 4500 PSI AND A MAXIMUM WATER CEMENT RATIO OF 0.426.
- ALL CONCRETE SHALL CONFORM TO ACI 301, "SPECIFICATIONS FOR STRUCTURAL CONCRETE FOR BUILDINGS" AND ACI 318, "BUILDING CODE REQUIREMENTS FOR REINFORCED CONCRETE AND COMMENTARY".
- PROVIDE 3/4" CHAMFERS ON ALL EXPOSED EDGES AND CORNERS UNLESS OTHERWISE NOTED.
- REINFORCING BARS SHALL CONFORM TO ASTM 615, GRADE 60, UNLESS OTHERWISE NOTED.
- CONCRETE COVER OVER REINFORCEMENT AND TIES, UNLESS OTHERWISE NOTED, SHALL BE AS FOLLOWS:
 - CAST AGAINST EARTH 3"
 - EXPOSED TO WEATHER 2"
- DEVELOPMENT AND SPICE LENGTH FOR REINFORCEMENT SHALL BE IN ACCORDANCE WITH ACI AND THE "REINFORCEMENT SPICE AND DEVELOPMENT LENGTH" TABLE INCLUDED IN THIS SET OF DRAWINGS.
- ALL DEVELOPMENT AND SPICE LENGTHS SHALL BE CATEGORY 1 UNLESS OTHERWISE NOTED ON DRAWINGS.
- ALL REINFORCING BARS WITH HOOKS SHALL BE PROVIDED WITH ACI STANDARD HOOKS UNLESS OTHERWISE NOTED. STANDARD HOOKS SHALL BE IN ACCORDANCE WITH "STANDARD HOOK FOR DEVELOPMENT TABLE" INCLUDED IN THIS SET OF DRAWINGS.
- BENDING OF REBAR SHALL BE IN ACCORDANCE WITH ACI AND "MINIMUM INSIDE BEND DIAMETERS AND STANDARD HOOK GEOMETRY FOR STIRRUPS, TIES AND HOOKS TABLE" INCLUDED IN THIS SET OF DRAWINGS.
- ALL FORMWORK FINISHES AND CONSTRUCTION JOINTS SHALL BE IN ACCORDANCE WITH THE NCDOT STANDARD SPECIFICATIONS.

STANDARD ABBREVIATIONS:

BOT	BOTTOM
T.O	TOP OF
B.O	BOTTOM OF
M.L.L.W	MEAN LOWER LOW WATER
M.H.H.W	MEAN HIGHER HIGH WATER
EL	ELEVATION
CL	CENTER LINE
PL	PLATE
EA.	EACH
Typ	TYPICAL
-	FEET
-	INCHES
STA	STATION
PSF	POUNDS PER SQUARE FOOT
DIA	DIAMETER
MIN	MINIMUM
MAX	MAXIMUM
DL	DEAD LOAD
LL	LIVE LOAD
ULL	UNIFORM LIVE LOAD
CLL	CONCENTRATED LIVE LOAD

Digitally signed by Kristopher P Pagan-Cruz
Date: 2026.05.01 16:32:29-04'00'

MOTT MACDONALD
930 Main Campus Drive,
Suite 200
Raleigh, NC 27606
License No. F-0669
T +1 (919) 552 2253
F +1 (919) 552 2254
www.mottmacamericas.com

GRAPHIC SCALE

Rev.	Date	Drawn	Description	Ch'kd	App'd

NCDOT HATTERAS FERRY DOCK REPLACEMENT

G-002 MARINE GENERAL NOTES (1 OF 2)

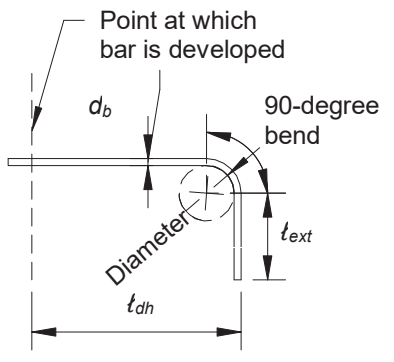
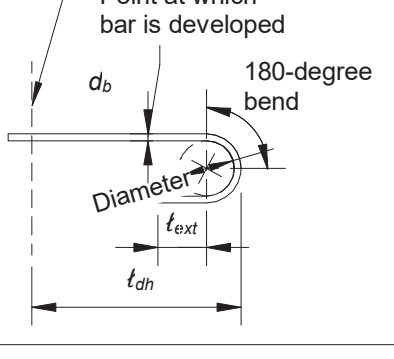
STANDARD HOOK FOR DEVELOPMENT TABLE				
Type of standard hook	Bar size	Minimum inside bend diameter, in.	Straight extension ⁽¹⁾ ℓ_{ext} , in.	Type of standard hook
90-degree hook	No. 3 through No. 8	$6d_b$	$12d_b$	
	No. 9 through No. 11	$8d_b$		
	No. 14 and No. 18	$10d_b$		
180-degree hook	No. 3 through No. 8	$6d_b$	Greater of $4d_b$ and 2.5 in.	
	No. 9 through No. 11	$8d_b$		
	No. 14 and No. 18	$10d_b$		

⁽¹⁾A STANDARD HOOK FOR DEFORMED BARS IN TENSION INCLUDES THE SPECIFIC INSIDE BEND DIAMETER AND STRAIGHT EXTENSION LENGTH. IT SHALL BE PERMITTED TO USE A LONGER STRAIGHT EXTENSION AT THE END OF A HOOK. A LONGER EXTENSION SHALL NOT BE CONSIDERED TO INCREASE THE ANCHORAGE CAPACITY OF THE HOOK.

REINFORCEMENT SPLICE AND DEVELOPMENT LENGTH (INCHES) TABLE (FOR 4000 PSI CONCRETE) (IN)											
CATEGORY			#3	#4	#5	#6	#7	#8	#9	#10	#11
			1	L.d	TOP	18	25	31	37	54	62
BOT	14	19			24	28	42	47	53	59	65
2	L.st	SPLICE	24	32	40	48	70	80	90	100	110
		L.d	TOP	28	37	46	55	81	92	104	116
	BOT	21	28	36	43	62	71	80	89	98	
	SPLICE	36	48	60	72	105	120	135	150	165	
	L.dh	HOOK	7	11	15	19	24	30	36	42	48

NOTES:
A. DEVELOPMENT AND SPLICE LENGTHS SHOWN IN TABLE ARE CALCULATED IN ACCORDANCE WITH ACI 318-19
B. TOP BARS ARE DEFINED AS HORIZONTAL REINFORCEMENT SO PLACED THAT MORE THAN 12 INCHES OF FRESH CONCRETE IS CAST BELOW THE BAR.
C. d_b STANDS FOR NOMINAL BAR DIAMETER
L.d STANDS FOR DEVELOPMENT LENGTH
L.st STANDS FOR SPLICE LENGTH
L.dh STANDS FOR DEVELOPMENT LENGTH OF BAR WITH STANDARD HOOK
D. CATEGORIES DEFINITIONS:
CATEGORY 1: CLEAR SPACING OF BARS OR WIRES BEING DEVELOPED OR LAP SPICED NOT LESS THAN d_b . CLEAR COVER AT LEAST d_b . AND STIRRUPS OR TIES THROUGHOUT L_d NOT LESS THAN THE CODE MIN OR CLEAR SPACING OF BARS OR WIRES BEING DEVELOPED OR LAP SPICED AT LEAST 2 d_b AND CLEAR COVER AT LEAST d_b .
CATEGORY 2: ALL OTHERS

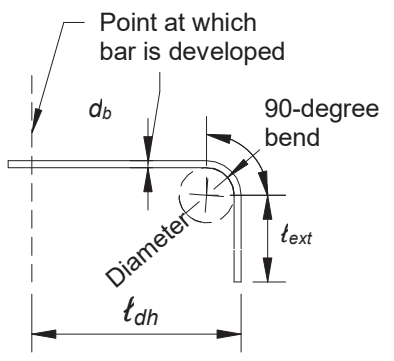
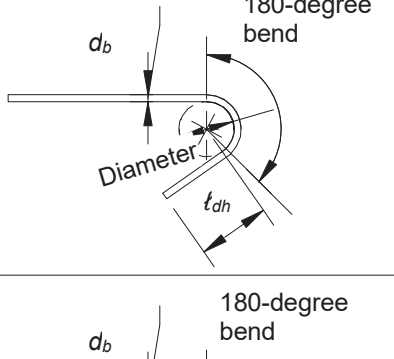
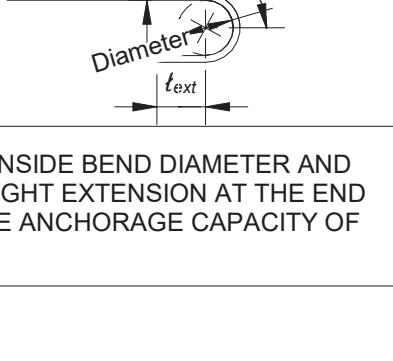
MIN. INSIDE BEND DIAMETERS AND STANDARD HOOK GEOMETRY FOR STIRRUPS, TIES AND HOOPS TABLE				
Type of standard hook	Bar size	Minimum inside bend diameter, in.	Straight extension ⁽¹⁾ ℓ_{ext} , in.	Type of standard hook
90-degree hook	No. 3 through No. 8	$6d_b$	$12d_b$	
	No. 9 through No. 11	$8d_b$		
	No. 14 and No. 18	$10d_b$		
135-degree hook	No. 3 through No. 5	$4d_b$	Greater of $6d_b$ and 3 in.	
	No. 6 through No. 8	$6d_b$		
180-degree hook	No. 3 through No. 5	$6d_b$	Greater of $4d_b$ and 2.5 in.	
	No. 6 through No. 8	$8d_b$		

⁽¹⁾A STANDARD HOOK FOR STIRRUPS, TIES, AND HOOPS INCLUDES THE SPECIFIC INSIDE BEND DIAMETER AND STRAIGHT EXTENSION LENGTH. IT SHALL BE PERMITTED TO USE A LONGER STRAIGHT EXTENSION AT THE END OF A HOOK. A LONGER EXTENSION SHALL NOT BE CONSIDERED TO INCREASE THE ANCHORAGE CAPACITY OF THE HOOK.

ANSI (D) (347-227)

Digitally signed by Kristopher P Pagan-Cruz
Date: 2026.02.17 11:18:16-05'00'

M M
MOTT MACDONALD
930 Main Campus Drive,
Suite 200
Raleigh, NC 27606
License No. F-0669
T +1 (919) 552 2253
F +1 (919) 552 2254
www.mottmacamericas.com

GRAPHIC SCALE

PROJECT ENGINEER

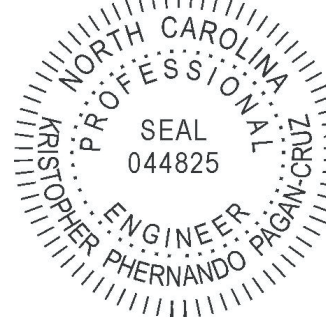

Designed By	JAVIER QUIROS	County	DARE COUNTY		
Entered By	VICTOR PADILLA	Division	FERRY DIVISION		
Project Engineer	KRISTOPHER PAGAN	Plan Date	01/14/26		
Project Manager	ALLISON THORBURN				
Rev.	Date	Drawn	Description	Ch'k'd	App'd

NCDOT HATTERAS FERRY DOCK REPLACEMENT

G-003 MARINE GENERAL NOTES
(2 OF 2)

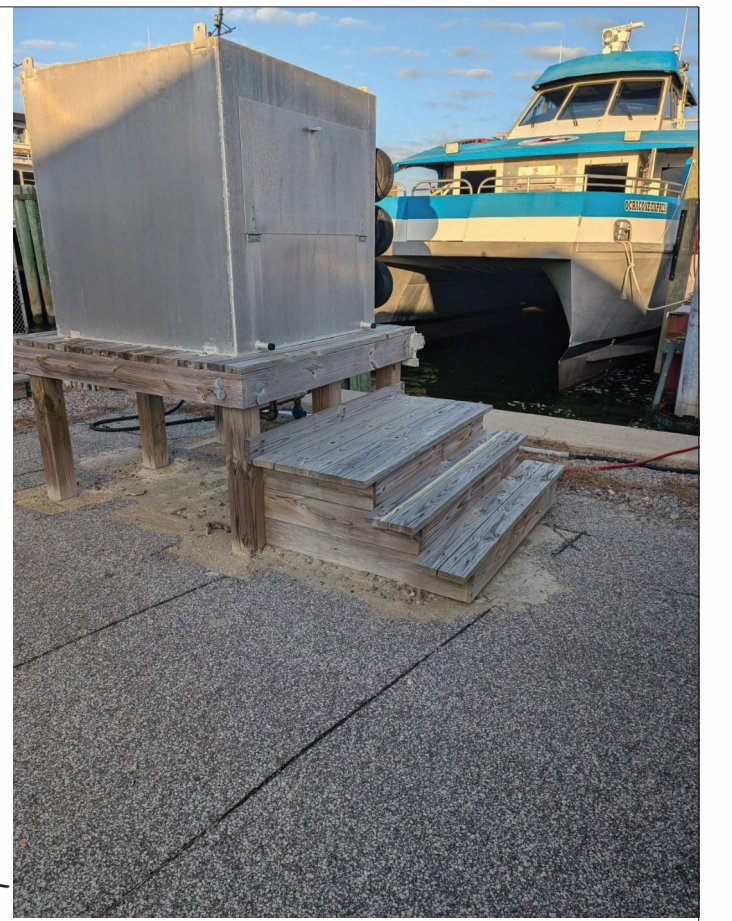
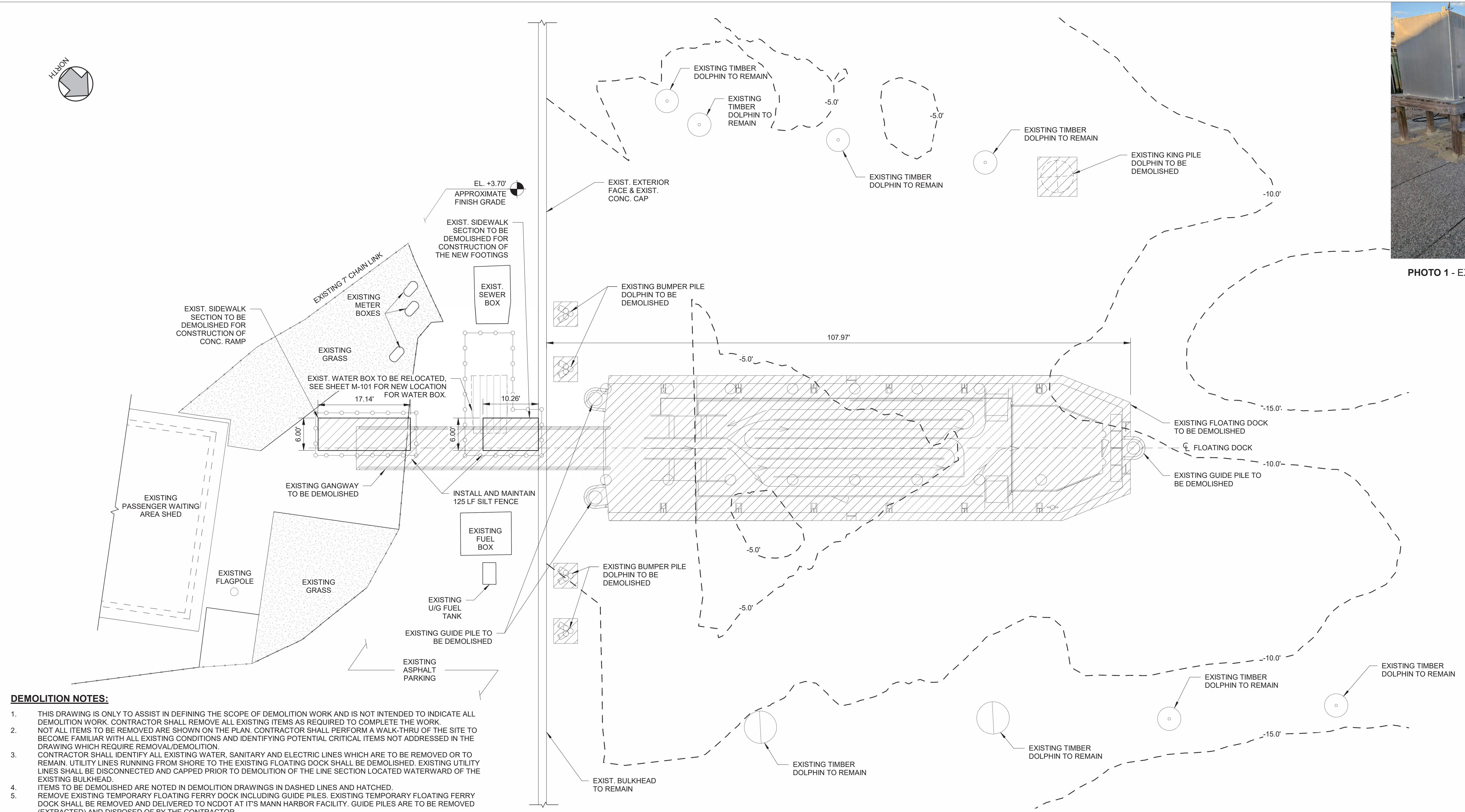

PHOTO 1 - EXISTING WATER BOX





DEMOLITION NOTES:

1. THIS DRAWING IS ONLY TO ASSIST IN DEFINING THE SCOPE OF DEMOLITION WORK AND IS NOT INTENDED TO INDICATE ALL DEMOLITION WORK. CONTRACTOR SHALL REMOVE ALL EXISTING ITEMS AS REQUIRED TO COMPLETE THE WORK.
2. NOT ALL ITEMS TO BE REMOVED ARE SHOWN ON THE PLAN. CONTRACTOR SHALL PERFORM A WALK-THRU OF THE SITE TO BECOME FAMILIAR WITH ALL EXISTING CONDITIONS AND IDENTIFYING POTENTIAL CRITICAL ITEMS NOT ADDRESSED IN THE DRAWING WHICH REQUIRE REMOVAL/DEMOLITION.
3. CONTRACTOR SHALL IDENTIFY ALL EXISTING WATER, SANITARY AND ELECTRIC LINES WHICH ARE TO BE REMOVED OR TO REMAIN. UTILITY LINES RUNNING FROM SHORE TO THE EXISTING FLOATING DOCK SHALL BE DEMOLISHED. EXISTING UTILITY LINES SHALL BE DISCONNECTED AND CAPPED PRIOR TO DEMOLITION OF THE LINE SECTION LOCATED WATERWARD OF THE EXISTING BULKHEAD.
4. ITEMS TO BE DEMOLISHED ARE NOTED IN DEMOLITION DRAWINGS IN DASHED LINES AND HATCHED.
5. REMOVE EXISTING TEMPORARY FLOATING FERRY DOCK INCLUDING GUIDE PILES. EXISTING TEMPORARY FLOATING FERRY DOCK SHALL BE REMOVED AND DELIVERED TO NCDOT AT ITS MANN HARBOR FACILITY. GUIDE PILES ARE TO BE REMOVED (EXTRACTED) AND DISPOSED OF BY THE CONTRACTOR.
6. EXECUTION OF DEMOLITION WORK SHALL PROGRESS IN SUCH A MANNER AS NOT TO INTERFERE WITH THE SAFETY AND CONVENIENCE OF THE PUBLIC AND PERSONNEL AT THE SITE.
7. WASTE AND RUBBISH FROM DEMOLITION WORK SHALL BE REMOVED FROM THE SITE AS RAPIDLY AS POSSIBLE AND SHALL NOT BE ALLOWED TO ACCUMULATE ON PREMISES.
8. IT IS NOT EXPECTED THAT HAZARDOUS MATERIAL WILL BE ENCOUNTERED DURING DEMOLITION WORK. IF MATERIALS SUSPECTED OF CONTAINING HAZARDOUS MATERIALS ARE IDENTIFIED OR ENCOUNTERED, STOP WORK AND DO NOT DISTURB, AND IMMEDIATELY NOTIFY IN WRITING THE OWNER AND ENGINEER.
9. SIDEWALK DEMOLITION SHALL BE CONDUCTED BY SAWCUTTING FULL DEPTH EXISTING SIDEWALK AREA TO BE REMOVED AT STRAIGHT LINES/EDGES. CONCRETE CUTTING SHALL BE ACCOMPLISHED IN A NEAT WORKMANLIKE MANNER.
10. IN THE EVENT SIDEWALK IS NOT CUT AT STRAIGHT LINES, THE CONTRACTOR SHALL PATCH AS NEEDED TO PROVIDE STRAIGHT AND SQUARE EDGES.
11. PILE DEMOLITION SHALL CONSIST OF PULLING (EXTRACTION) OF THE PILES FROM THE GROUND.
12. AREA TO BE DREDGED SHOWN IN THE DEMOLITION PLAN CONSISTS OF APPROXIMATELY 59,500 SF AREA WITH AN ESTIMATED 74,000 CF OF SHOALED MATERIAL TO BE DREDGED. SHOALED MATERIAL SHALL BE REMOVED FROM WITHIN THE DREDGING AREA TO A BOTTOM GRADE ELEVATION OF -10.0' MLLW. TO FACILITATE DREDGING DOWN TO THE REQUIRED DEPTH CONTRACTOR MAY DISTURB ONE (1) FOOT BELOW THE REQUIRED DEPTH SHOWN ON THE DRAWINGS. TOTAL AREA TO BE DREDGED CONSISTS OF THE BOX AREA MARKED ON THE DRAWING PLUS SIDE SLOPES NO FLATTER THAN 1 VERTICAL TO 3 HORIZONTAL.
13. DEBRIS SHALL BE REMOVED FROM THE WORK AREA ON A DAILY BASIS TO ENSURE NO ENVIRONMENTAL IMPACT. DISPOSAL OF ALL MATERIALS REMOVED AND/OR DEMOLISHED SHALL BE THE RESPONSIBILITY OF THE CONTRACTOR AND BE PERFORMED LEGALLY AND SAFELY AT AN APPROVED DISPOSAL FACILITY.
14. THE EXISTING WATER BOX IS TO BE RELOCATED BY THE CONTRACTOR. THE RELOCATED WATER BOX LOCATION SHOWN IN SHEET M-101 IS INDICATIVE. FINAL WATER BOX LOCATION SHALL BE COORDINATED WITH NCDOT BY THE CONTRACTOR. PHOTO 1 SHOWS THE EXISTING WATER BOX.
15. THE REMOVING OF SIDEWALK SLAB ON GRADE OR ASPHALT PAVEMENT REQUIRES SAWCUTTING. AREAS TO BE DEMOLISHED SHALL BE SQUARED OFF AND SHALL CONSIDER REPATCHING WORK AFTER THE DEMO AND CONSTRUCTION WORK IS COMPLETED. AREAS TO REMAIN SHALL BE PROTECTED.
16. EROSION CONTROL MEASURES SHOWN SHALL BE CONSIDERED TO BE THE MINIMUM INSTALLATION REQUIREMENT. THE CONTRACTOR SHALL PROVIDE ANY MATERIAL ITEM OR WORK EFFORT NECESSARY TO PREVENT EROSION AND MAINTAIN SEDIMENT ON SITE AT ALL TIMES DURING CONSTRUCTION.
17. CONTRACTOR SHALL BE SOLELY RESPONSIBLE FOR CONTROLLING EROSION AND SEDIMENTATION WITHIN ITS WORK AREAS. FAILURE TO PREVENT EROSION AND MAINTAIN SEDIMENT ON SITE MAY RESULT IN REGULATORY ENFORCEMENT ACTIONS AND/OR CIVIL PENALTIES/FINES. THE CONTRACTOR SHALL BEAR THE COSTS OF ANY ENFORCEMENT ACTION, PENALTIES, AND/OR FINES AT NO ADDITIONAL COST TO THE OWNER.
18. A PHOTO OF THE EXISTING WATER BOX TO BE RELOCATED IS INCLUDED IN THIS SHEET FOR REFERENCE, AS PHOTO 1.

1 EXISTING CONDITIONS AND DEMOLITION - PLAN
1" = 10'-0"

DEMOLITION LEGEND:

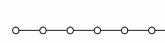
-  EXISTING TO REMAIN
-  EXISTING TO BE DEMOLISHED
-  EXISTING TO BE RELOCATED
-  NEW SILT FENCE

Digitally signed by Kristopher P Pagan-Cruz
Date: 2026.02.17 11:18:24-05'00'

MOTT MACDONALD
930 Main Campus Drive,
Suite 200
Raleigh, NC 27606
License No. F-0669
F +1 (919) 552 2254
www.mottmacamericas.com

GRAPHIC SCALE
0 5' 10' 20'
SCALE: 1" = 10'-0"

PROJECT ENGINEER
NORTH CAROLINA PROFESSIONAL SEAL
K. P. PAGAN-CRUZ
044825

Designed By	JAVIER QUIROS	County	DARE COUNTY
Entered By	VICTOR PADILLA	Division	FERRY DIVISION
Project Engineer	KRISTOPHER PAGAN	Plan Date	1-14-26
Project Manager	ALLISON THORBURN		
Rev.	Date	Drawn	Description
			Ch'k'd
			App'd

NCDOT HATTERAS FERRY DOCK REPLACEMENT

D-101 EXISTING CONDITIONS AND DEMOLITION PLAN

ANSI D (9/19/22)

NOT USED

M
MOTT
MACDONALD

930 Main Campus Drive,
Suite 200
Raleigh, NC 27606
License No. F-0669
T +1 (919) 552 2253
F +1 (919) 552 2254
www.mottmacamericas.com

GRAPHIC SCALE

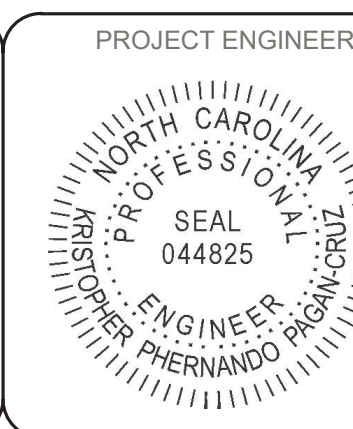

Rev.	Date	Drawn	Description	Ch'kd	App'd

NCDOT HATTERAS FERRY DOCK
REPLACEMENT

D-102 NOT USED

NOT USED

M
MOTT
MACDONALD

930 Main Campus Drive,
Suite 200
Raleigh, NC 27606
License No. F-0669
T +1 (919) 552 2253
F +1 (919) 552 2254
www.mottmacamericas.com

GRAPHIC SCALE

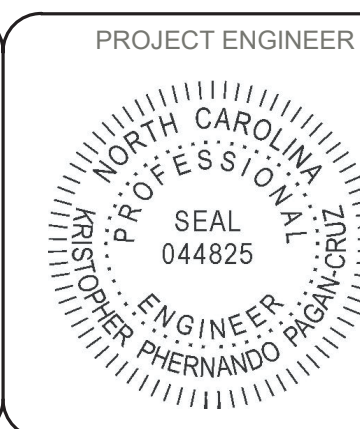

Rev.	Date	Drawn	Description	Ch'kd	App'd

NCDOT HATTERAS FERRY DOCK
REPLACEMENT

D-103 NOT USED

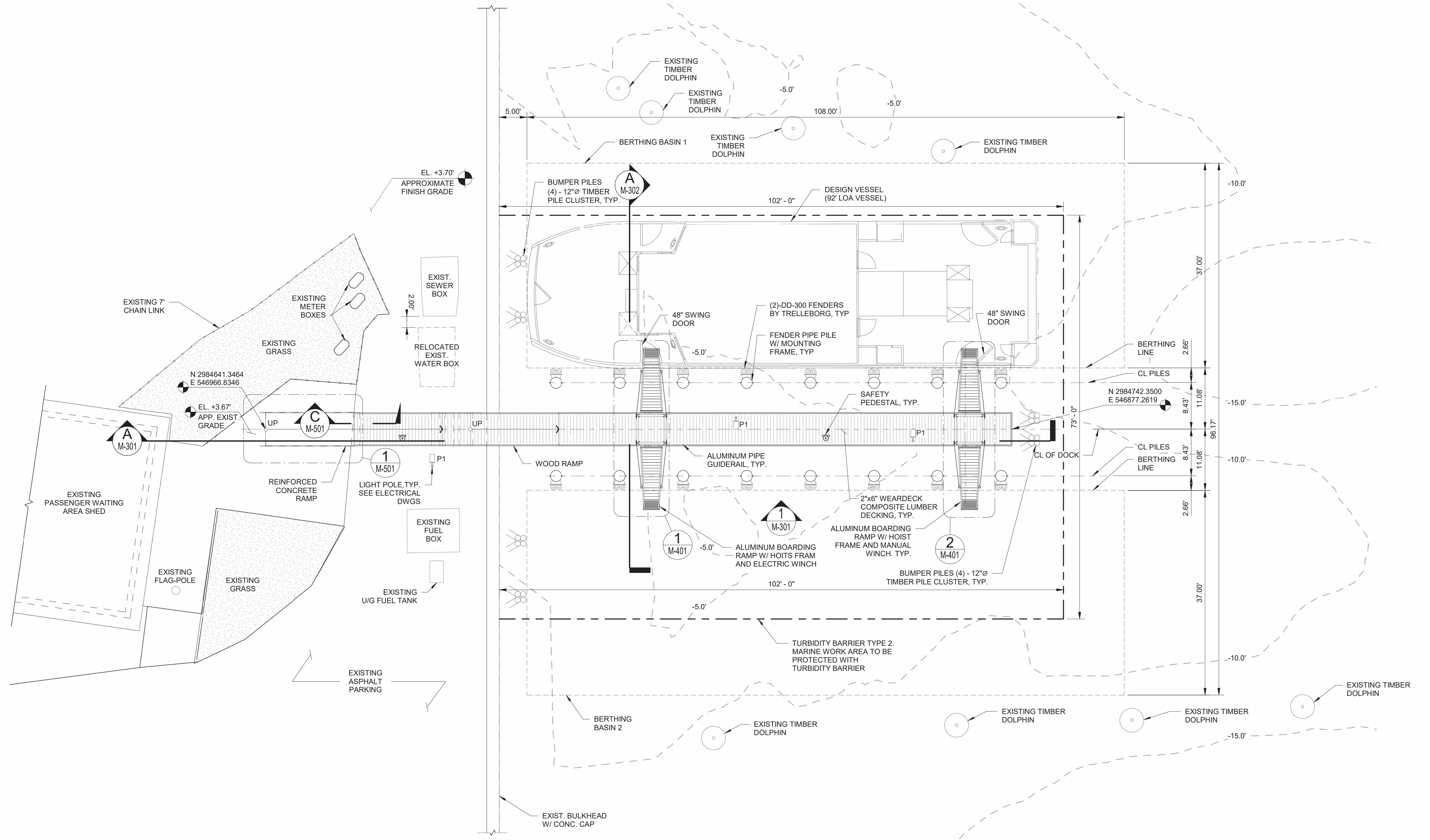

NOTES:

- EXISTING WATER BOX TO BE RELOCATED BY CONTRACTOR. LOCATION SHOWN IN PLAN IS INDICATIVE AND FOR REFERENCE ONLY. FINAL LOCATION TO BE COORDINATED WITH NCDOT BY THE CONTRACTOR. WATER BOX RELOCATION WORK SHALL INCLUDE RELOCATION OF EXISTING ITEMS AND CONSTRUCTION OF NEW ITEMS THAT ARE NEEDED TO REPLACE THOSE THAT CANNOT BE RELOCATED. WORK RELATED TO NEW ITEMS INCLUDES: EXCAVATION AND CONSTRUCTION OF NEW CONCRETE FOOTINGS, NEW WOOD POSTS TO REPLACE EXISTING POSTS, NEW WATER CONNECTION AND EXTENSION OF SUPPLY PIPE TO NEW LOCATION SLAB ON GRADE TO REPLACE REQUIRED DEMOLITION OF AREA, AND NEW STAIRS. RECONSTRUCTION OF NEW ITEMS SHALL BE IN KIND FOR FOOTING DETAILS SEE SHEET M-505.
- COMPOSITE LUMBER DECKING SHALL BE 2"x6" WEARDECK COMPOSITE LUMBER DECKING BY OWENS CORNING OR EQUAL.
- CONTOURS SHOWN ARE FOR EXISTING MUDLINE DEPTHS.

1 MARINE OVERALL SITE - PLAN
1" = 10'-0"

Digitally signed by Kristopher P Pagan-Cruz
Date: 2026.05.01 16:33:09-04'00'

M M
MOTT MACDONALD
930 Main Campus Drive,
Suite 200
Raleigh, NC 27606
License No. F-0669
T +1 (919) 552 2253
F +1 (919) 552 2254
www.mottmacamericas.com

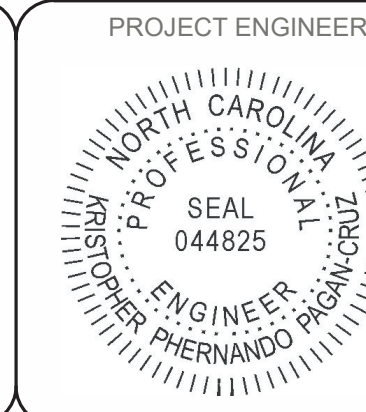
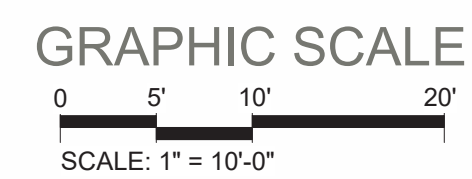

Rev.	Date	Drawn	Description	Ch'k'd	App'd

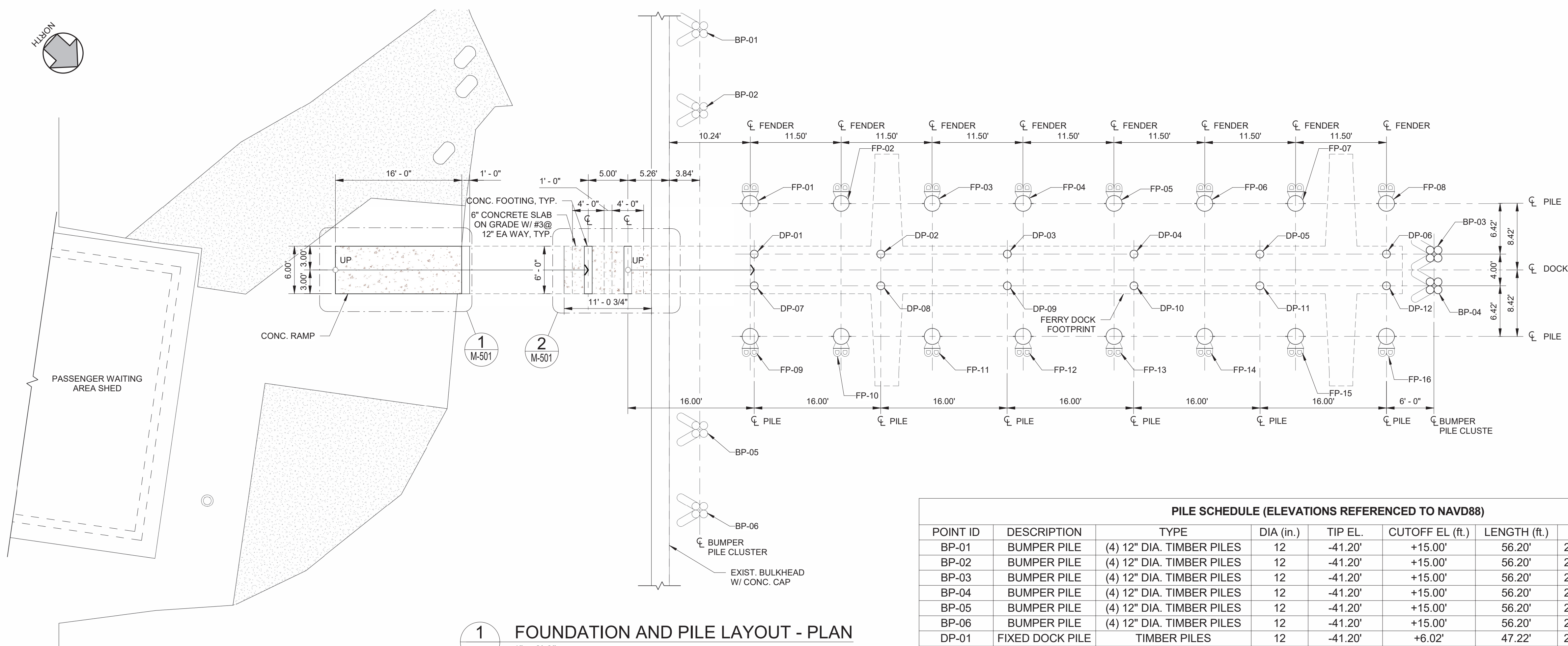

NCDOT HATTERAS FERRY DOCK REPLACEMENT

M-101 MARINE OVERALL SITE PLAN



1 FOUNDATION AND PILE LAYOUT - PLAN
1" = 8'-0"

LEGEND:

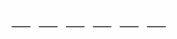
-  NEW CONCRETE RAMP OR SLAB ON GRADE
-  NEW CONCRETE FOOTING
-  NEW DOCK FOOTPRINT

NOTES:

1. BUMPER PILE CLUSTER CONSISTS OF 2 PLUMB PILES AND 2 BATTER PILES. SEE DETAIL IN SHEET M-504.
2. LENGTH OF PILES FOR BUMPER PILES IS 56.20' FOR PLUMB PILES AND 56.39' FOR BATTER PILES.
3. FOR SLAB ON GRADE DETAILS, SEE SHEET M-505.

PILE SCHEDULE (ELEVATIONS REFERENCED TO NAVD88)								
POINT ID	DESCRIPTION	TYPE	DIA (in.)	TIP EL.	CUTOFF EL (ft.)	LENGTH (ft.)	NORTHING	EASTING
BP-01	BUMPER PILE	(4) 12" DIA. TIMBER PILES	12	-41.20'	+15.00'	56.20'	2,984,655.6850	546,913.5293
BP-02	BUMPER PILE	(4) 12" DIA. TIMBER PILES	12	-41.20'	+15.00'	56.20'	2,984,662.4411	546,921.1476
BP-03	BUMPER PILE	(4) 12" DIA. TIMBER PILES	12	-41.20'	+15.00'	56.20'	2,984,744.0157	546,873.1115
BP-04	BUMPER PILE	(4) 12" DIA. TIMBER PILES	12	-41.20'	+15.00'	56.20'	2,984,746.6720	546,876.1068
BP-05	BUMPER PILE	(4) 12" DIA. TIMBER PILES	12	-41.20'	+15.00'	56.20'	2,984,689.2273	546,951.3522
BP-06	BUMPER PILE	(4) 12" DIA. TIMBER PILES	12	-41.20'	+15.00'	56.20'	2,984,695.9834	546,958.9705
DP-01	FIXED DOCK PILE	TIMBER PILES	12	-41.20'	+6.02'	47.22'	2,984,679.6726	546,930.1727
DP-02	FIXED DOCK PILE	TIMBER PILES	12	-41.20'	+6.02'	47.22'	2,984,691.6434	546,919.5567
DP-03	FIXED DOCK PILE	TIMBER PILES	12	-41.20'	+6.02'	47.22'	2,984,703.6142	546,908.9406
DP-04	FIXED DOCK PILE	TIMBER PILES	12	-41.20'	+6.02'	47.22'	2,984,715.5851	546,898.3245
DP-05	FIXED DOCK PILE	TIMBER PILES	12	-41.20'	+6.02'	47.22'	2,984,727.5558	546,887.7086
DP-06	FIXED DOCK PILE	TIMBER PILES	12	-41.20'	+6.02'	47.22'	2,984,739.5266	546,877.0925
DP-07	FIXED DOCK PILE	TIMBER PILES	12	-41.20'	+6.02'	47.22'	2,984,682.3267	546,933.1654
DP-08	FIXED DOCK PILE	TIMBER PILES	12	-41.20'	+6.02'	47.22'	2,984,694.2999	546,922.5471
DP-09	FIXED DOCK PILE	TIMBER PILES	12	-41.20'	+6.02'	47.22'	2,984,706.2682	546,911.9333
DP-10	FIXED DOCK PILE	TIMBER PILES	12	-41.20'	+6.02'	47.22'	2,984,718.2390	546,901.3173
DP-11	FIXED DOCK PILE	TIMBER PILES	12	-41.20'	+6.02'	47.22'	2,984,730.2098	546,890.7013
DP-12	FIXED DOCK PILE	TIMBER PILES	12	-41.20'	+6.02'	47.22'	2,984,742.1806	546,880.0852
FP-01	FENDER PILE	STEEL PIPE PILE	24	-62.0'	+15.00'	77.00'	2,984,675.0342	546,925.6959
FP-02	FENDER PILE	STEEL PIPE PILE	24	-62.0'	+15.00'	77.00'	2,984,683.6385	546,918.0653
FP-03	FENDER PILE	STEEL PIPE PILE	24	-62.0'	+15.00'	77.00'	2,984,692.2422	546,910.4353
FP-04	FENDER PILE	STEEL PIPE PILE	24	-62.0'	+15.00'	77.00'	2,984,700.8462	546,902.8051
FP-05	FENDER PILE	STEEL PIPE PILE	24	-62.0'	+15.00'	77.00'	2,984,709.4505	546,895.1745
FP-06	FENDER PILE	STEEL PIPE PILE	24	-62.0'	+15.00'	77.00'	2,984,718.0542	546,887.5445
FP-07	FENDER PILE	STEEL PIPE PILE	24	-62.0'	+15.00'	77.00'	2,984,726.6582	546,879.9143
FP-08	FENDER PILE	STEEL PIPE PILE	24	-62.0'	+15.00'	77.00'	2,984,735.2626	546,872.2837
FP-09	FENDER PILE	STEEL PIPE PILE	24	-62.0'	+15.00'	77.00'	2,984,686.2169	546,938.3057
FP-10	FENDER PILE	STEEL PIPE PILE	24	-62.0'	+15.00'	77.00'	2,984,694.8213	546,930.6751
FP-11	FENDER PILE	STEEL PIPE PILE	24	-62.0'	+15.00'	77.00'	2,984,703.4249	546,923.0452
FP-12	FENDER PILE	STEEL PIPE PILE	24	-62.0'	+15.00'	77.00'	2,984,712.0290	546,915.4149
FP-13	FENDER PILE	STEEL PIPE PILE	24	-62.0'	+15.00'	77.00'	2,984,720.6333	546,907.7843
FP-14	FENDER PILE	STEEL PIPE PILE	24	-62.0'	+15.00'	77.00'	2,984,729.2370	546,900.1543
FP-15	FENDER PILE	STEEL PIPE PILE	24	-62.0'	+15.00'	77.00'	2,984,737.8410	546,892.5241
FP-16	FENDER PILE	STEEL PIPE PILE	24	-62.0'	+15.00'	77.00'	2,984,746.4453	546,884.8935

Digitally signed by Kristopher P Pagan-Cruz
Date: 2026.02.17 11:19:23-05'00'

M M
MOTT MACDONALD
930 Main Campus Drive,
Suite 200
Raleigh, NC 27606
License No. F-0669
T +1 (919) 552 2253
F +1 (919) 552 2254
www.mottmacamericas.com

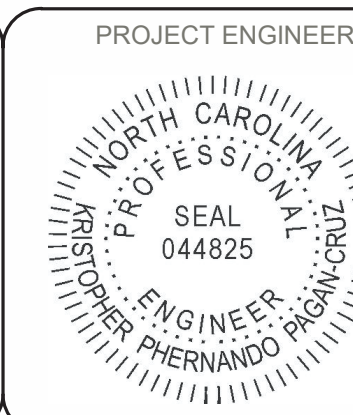
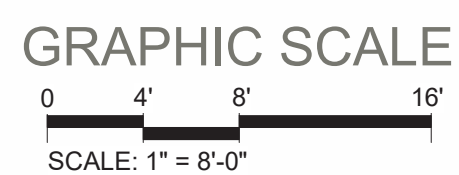

Rev.	Date	Drawn	Description	Ch'k'd	App'd

NCDOT HATTERAS FERRY DOCK REPLACEMENT

M-102 FOUNDATION AND PILE LAYOUT PLAN

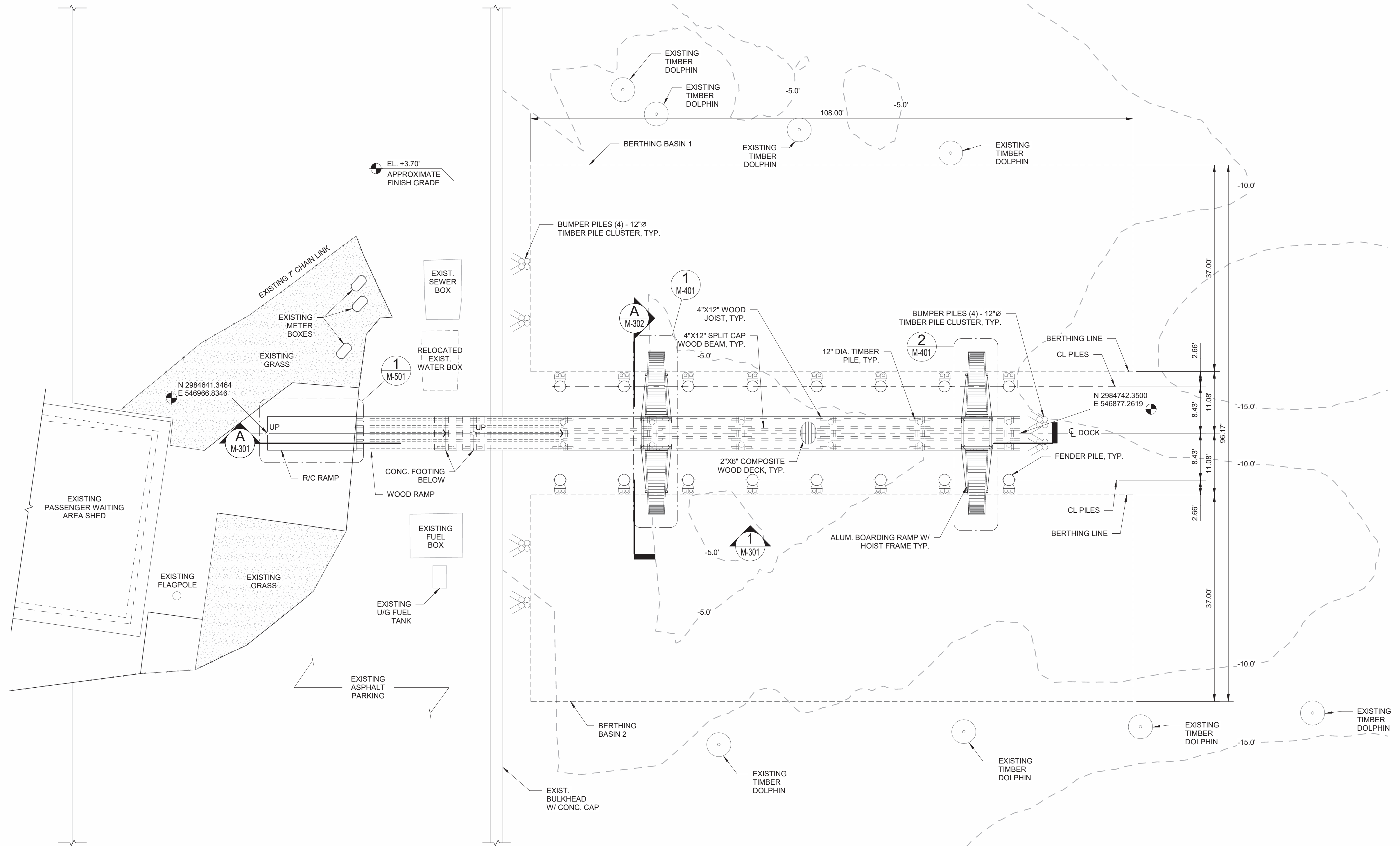

NOTES:

- 1. CONTOURS SHOWN ARE FOR EXISTING MUDLINE DEPTHS.

1 PIER FRAMING PLAN
1" = 10'-0"

Digitally signed by Kristopher P Pagan-Cruz
Date: 2026.02.17 11:19:32-05'00'

M M
MOTT MACDONALD
930 Main Campus Drive,
Suite 200
Raleigh, NC 27606
License No. F-0669
T +1 (919) 552 2253
F +1 (919) 552 2254
www.mottmacamericas.com

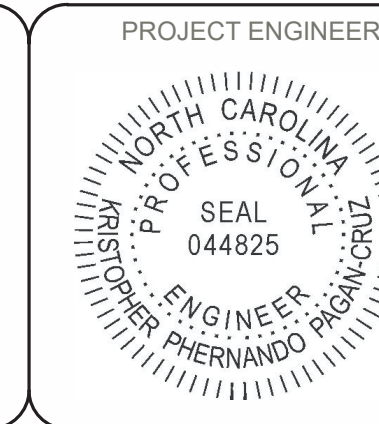
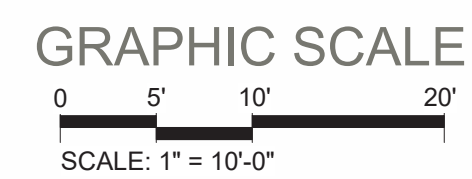

PROJECT ENGINEER	Designed By	JAVIER QUIROS	County	DARE COUNTY
	Entered By	VICTOR PADILLA	Division	FERRY DIVISION
	Project Engineer	KRISTOPHER PAGAN	Plan Date	1-14-26
	Project Manager	ALLISON THORBURN		
Rev.	Date	Drawn	Description	Ch'k'd
				App'd

NCDOT HATTERAS FERRY DOCK REPLACEMENT

M-103 PIER FRAMING PLAN

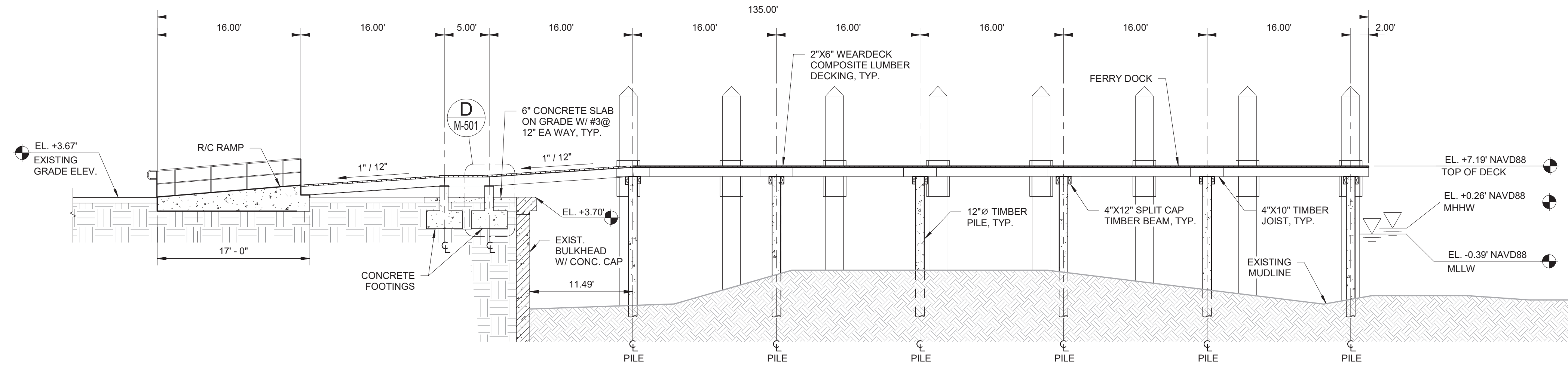

A LONGITUDINAL - SECTION
M-101 1" = 8'-0"

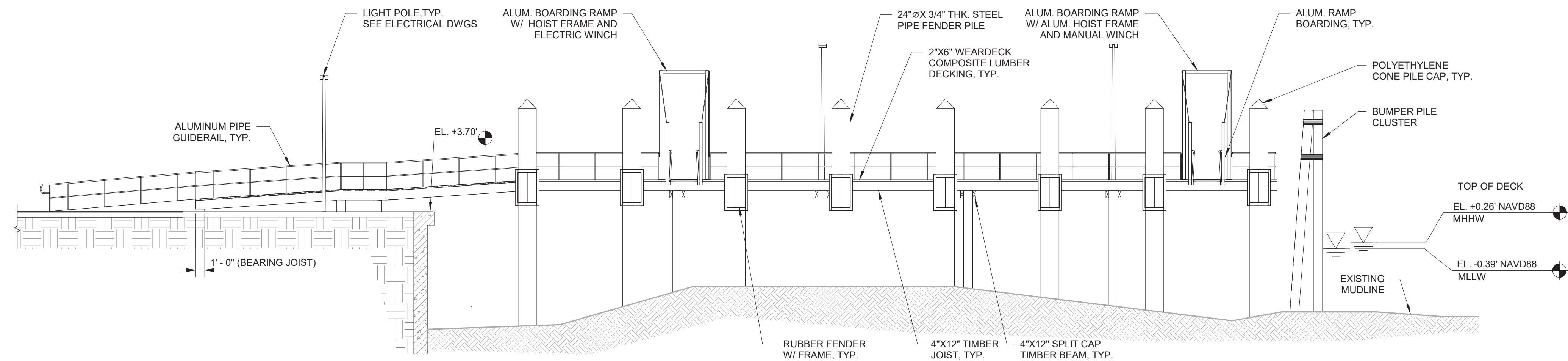

1 ELEVATION
M-101 1" = 8'-0"

LEGEND

- INDICATES EXISTING CONCRETE
- INDICATES NEW CONCRETE

Digitally signed by Kristopher P Pagan-Cruz
Date: 2026.05.01 16:33:40-04'00'

M M
MOTT MACDONALD
930 Main Campus Drive,
Suite 200
Raleigh, NC 27606
License No. F-0669
T +1 (919) 552 2253
F +1 (919) 552 2254
www.mottmacamericas.com

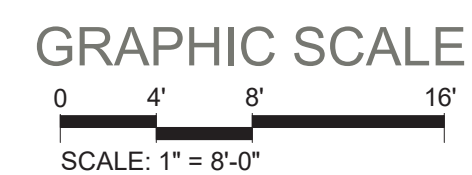

PROJECT ENGINEER	Designed By	JAVIER QUIROS	County	DARE COUNTY	
	Entered By	VICTOR PADILLA	Division	FERRY DIVISION	
	Project Engineer	KRISTOPHER PAGAN	Plan Date	1-14-26	
	Project Manager	ALLISON THORBURN			
Rev.	Date	Drawn	Description	Ch'kd	App'd

NCDOT HATTERAS FERRY DOCK REPLACEMENT

M-301 LONGITUDINAL SECTION & ELEVATION

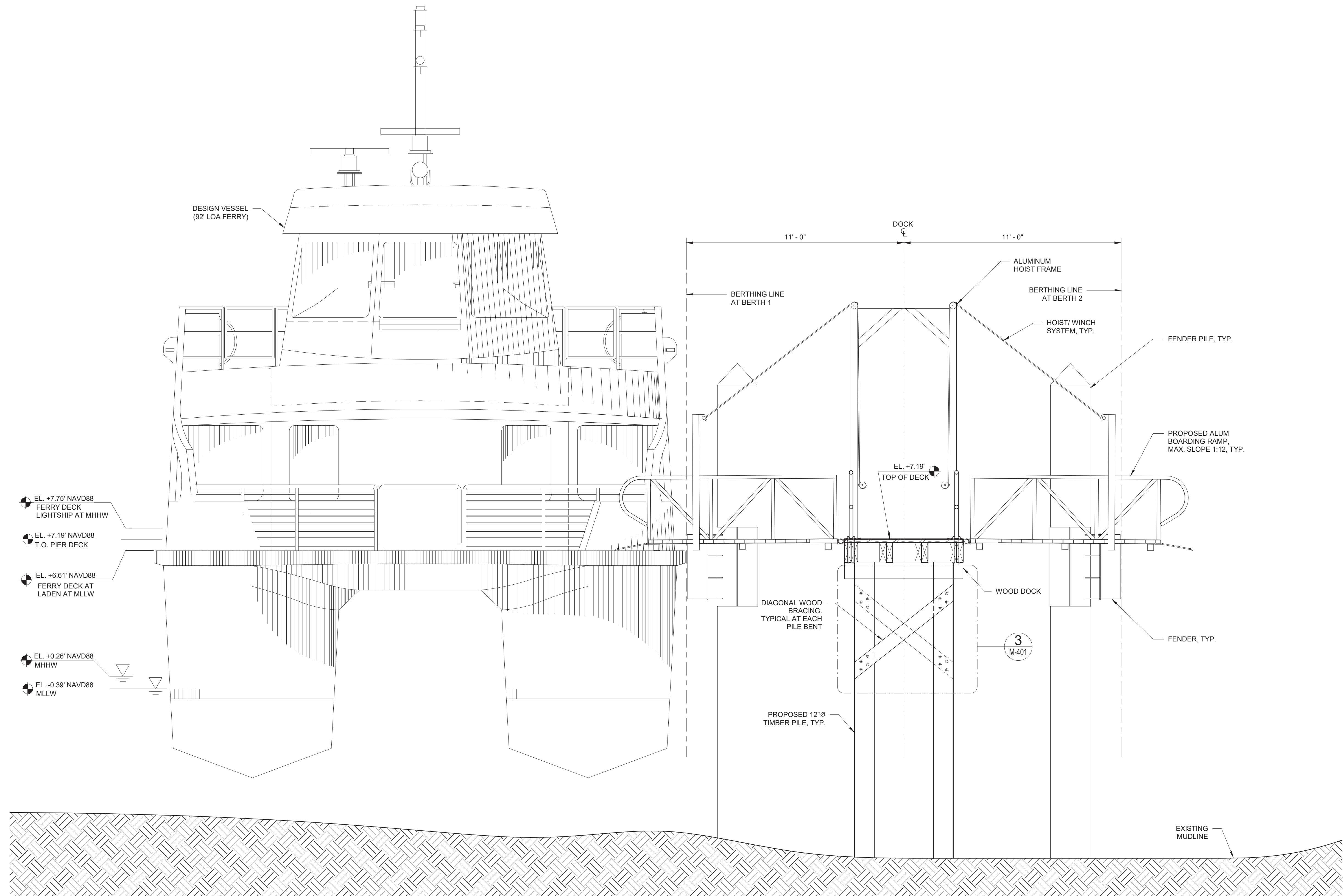

- EL. +7.75' NAVD88
FERRY DECK
LIGHTSHIP AT MHHW
- EL. +7.19' NAVD88
T.O. PIER DECK
- EL. +6.61' NAVD88
FERRY DECK AT
LADEN AT MLLW
- EL. +0.26' NAVD88
MHHW
- EL. -0.39' NAVD88
MLLW

A TRANSVERSE - SECTION
M-101 1" = 2'-8"

Digitally signed by Kristopher P Pagan-Cruz
Date: 2026.05.01 16:34:05-04'00'

M M
MOTT MACDONALD
930 Main Campus Drive,
Suite 200
Raleigh, NC 27606
License No. F-0669
T +1 (919) 552 2253
F +1 (919) 552 2254
www.mottmacamericas.com

GRAPHIC SCALE
0 1' 3' 5'
SCALE: 1" = 2'-8"

PROJECT ENGINEER	Designed By	JAVIER QUIROS	County	DARE COUNTY
	Entered By	VICTOR PADILLA	Division	FERRY DIVISION
	Project Engineer	KRISTOPHER PAGAN	Plan Date	1-14-26
	Project Manager	ALLISON THORBURN		
	Rev.	Date	Drawn	Description
				Ch'kd
				App'd

NCDOT HATTERAS FERRY DOCK REPLACEMENT

M-302 TRANSVERSE SECTION

ANSI D (94'x22')

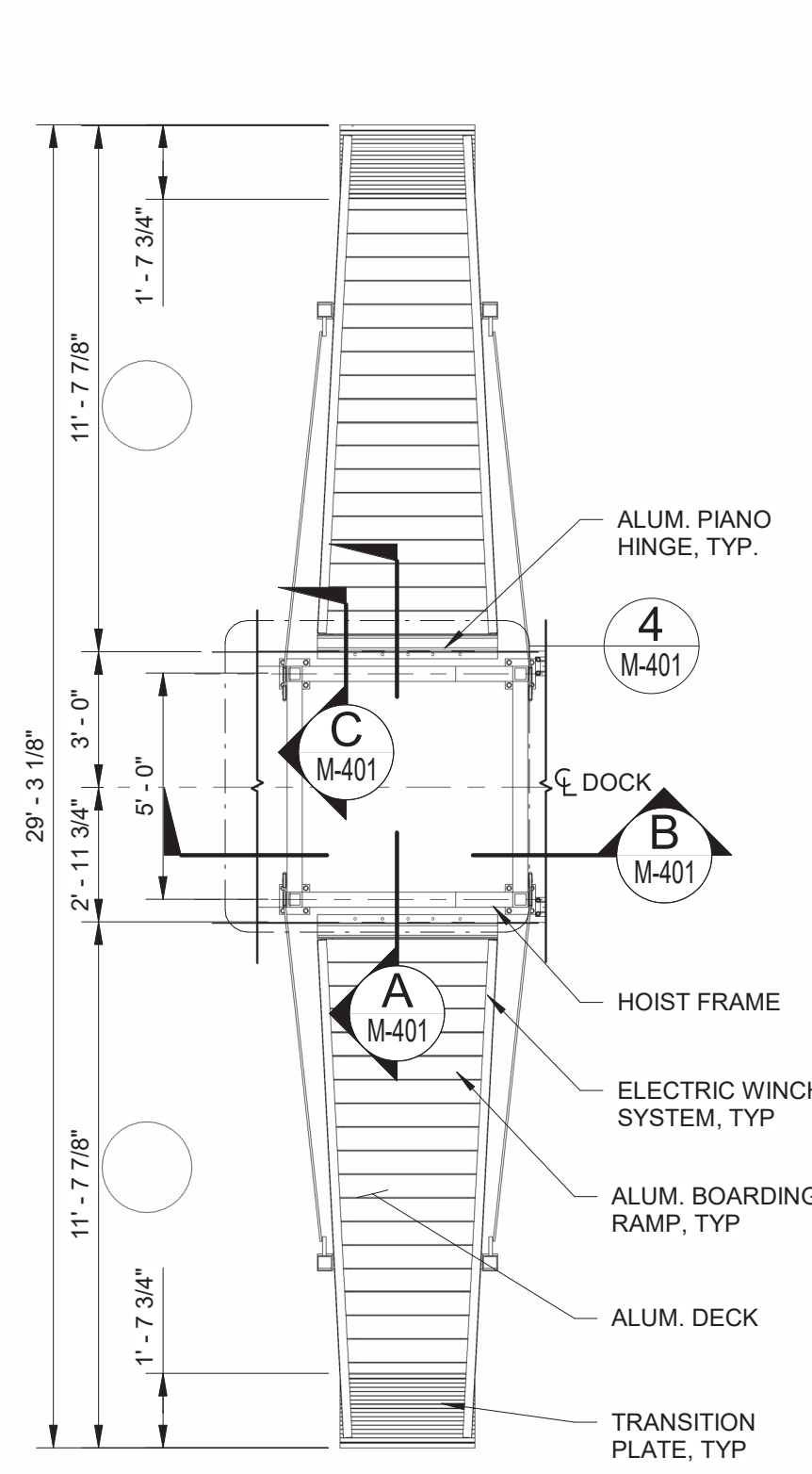

1 ENLARGED PLAN RAMP DETAIL
M-101 1" = 4'-0"

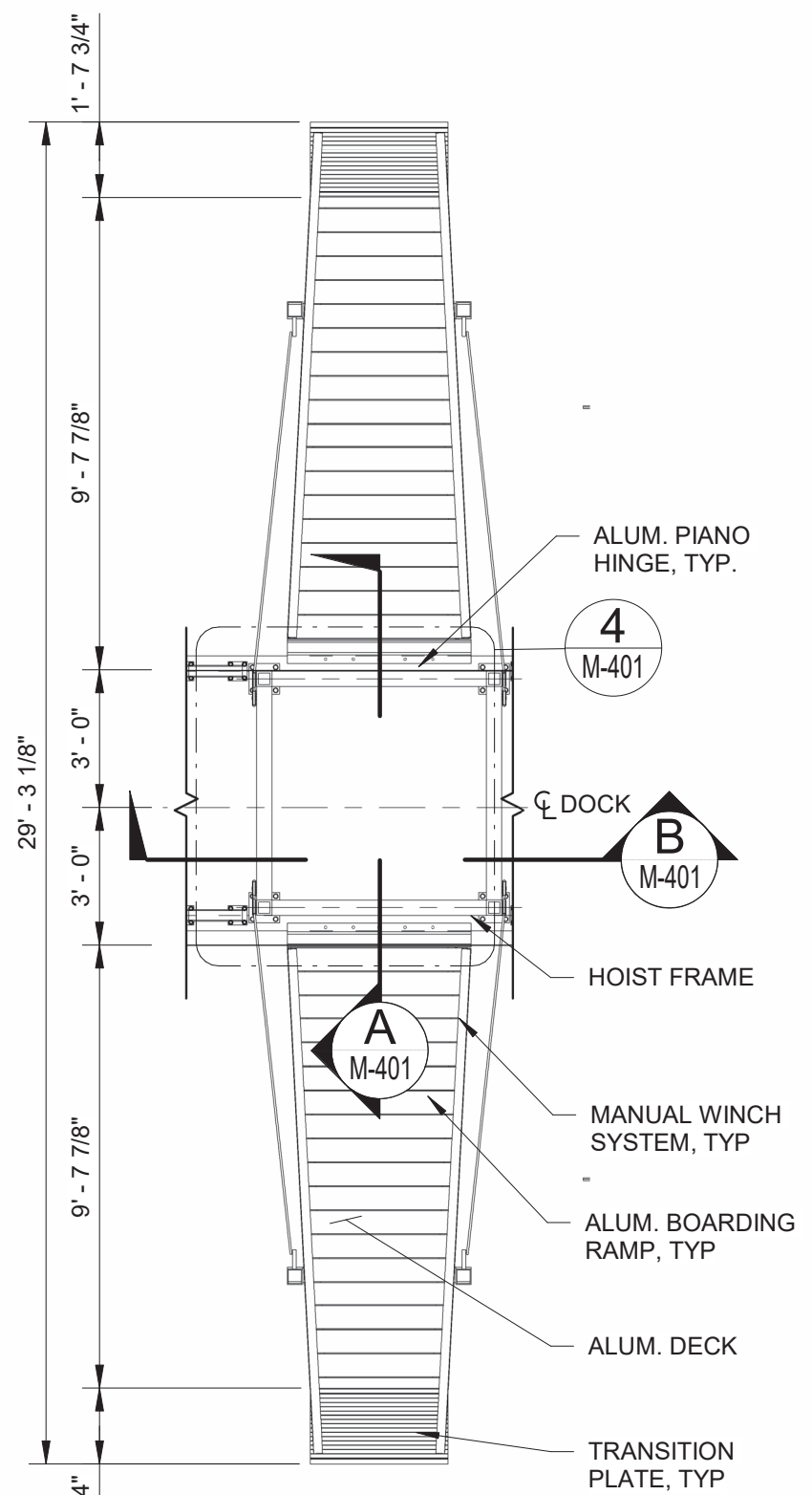

2 ENLARGED PLAN RAMP DETAIL
M-101 1" = 4'-0"

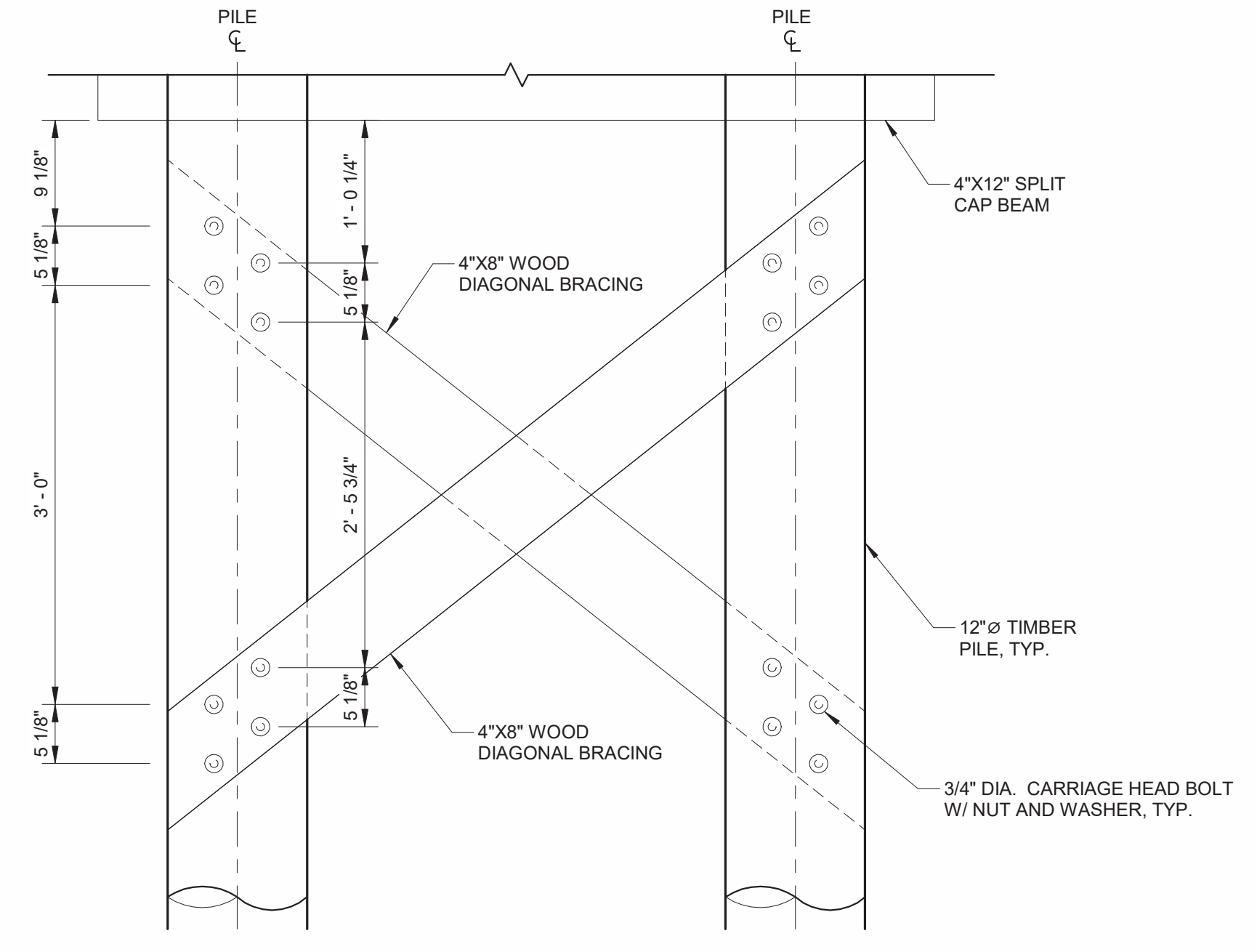

3 LATERAL BRACING DETAIL
M-302 1" = 1'-0"

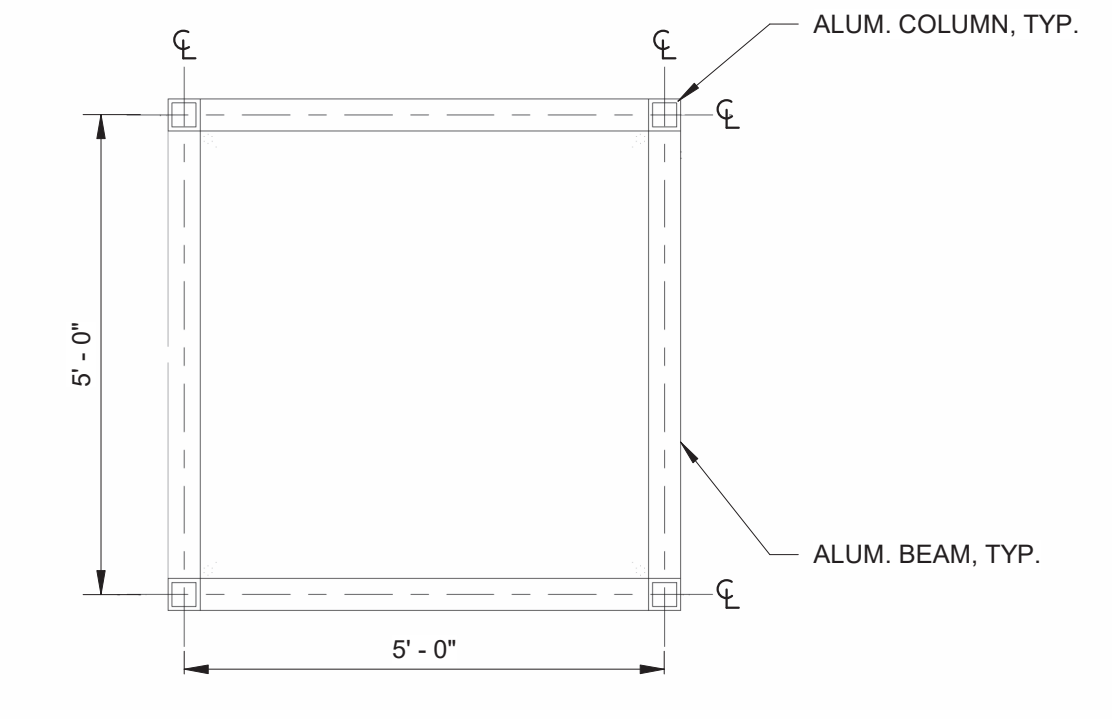

4 ENLARGED HOIST FRAME PLAN
M-401 1" = 2'-0"

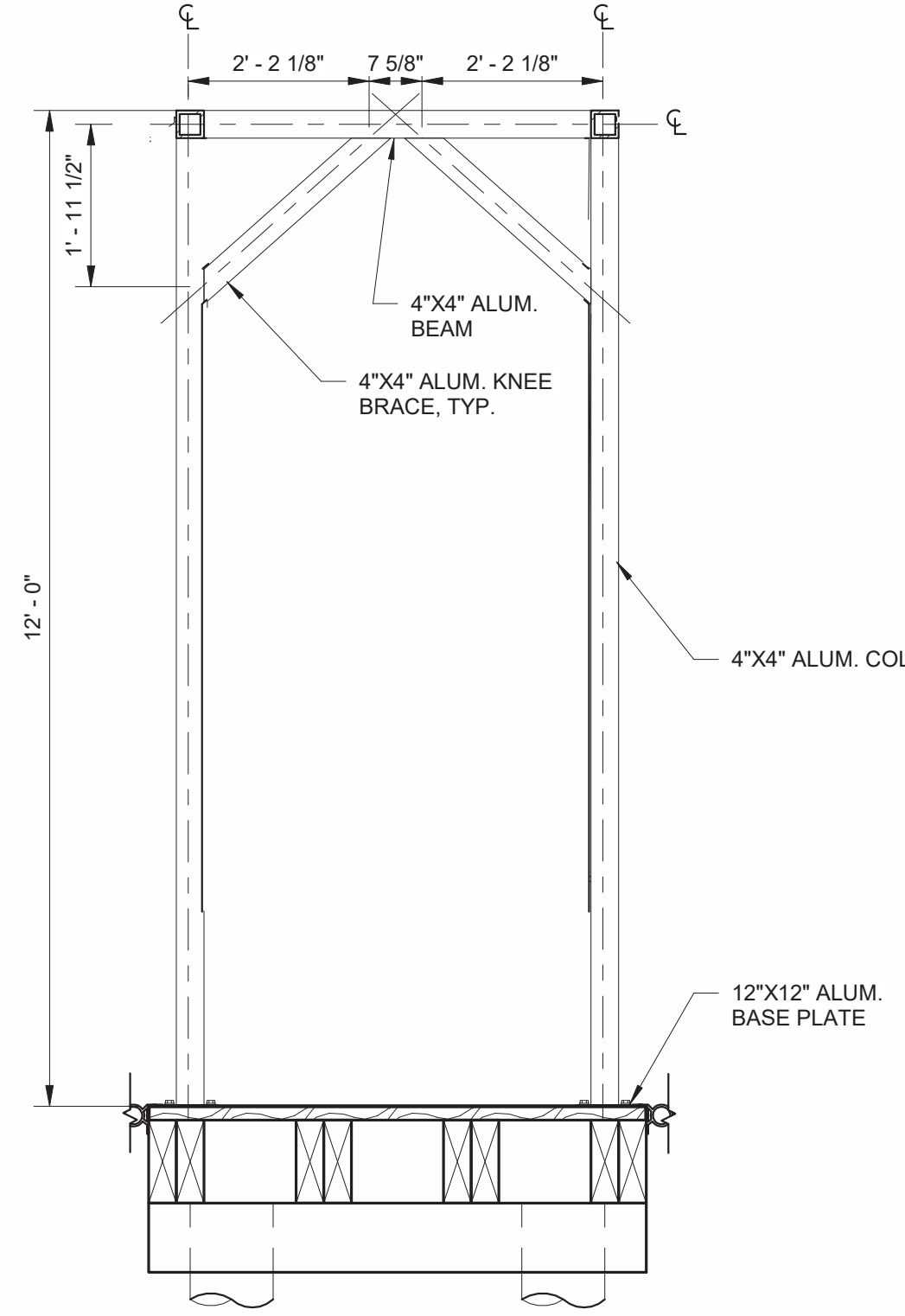

A ENLARGED HOIST FRAME SECTION
M-401 1" = 2'-0"

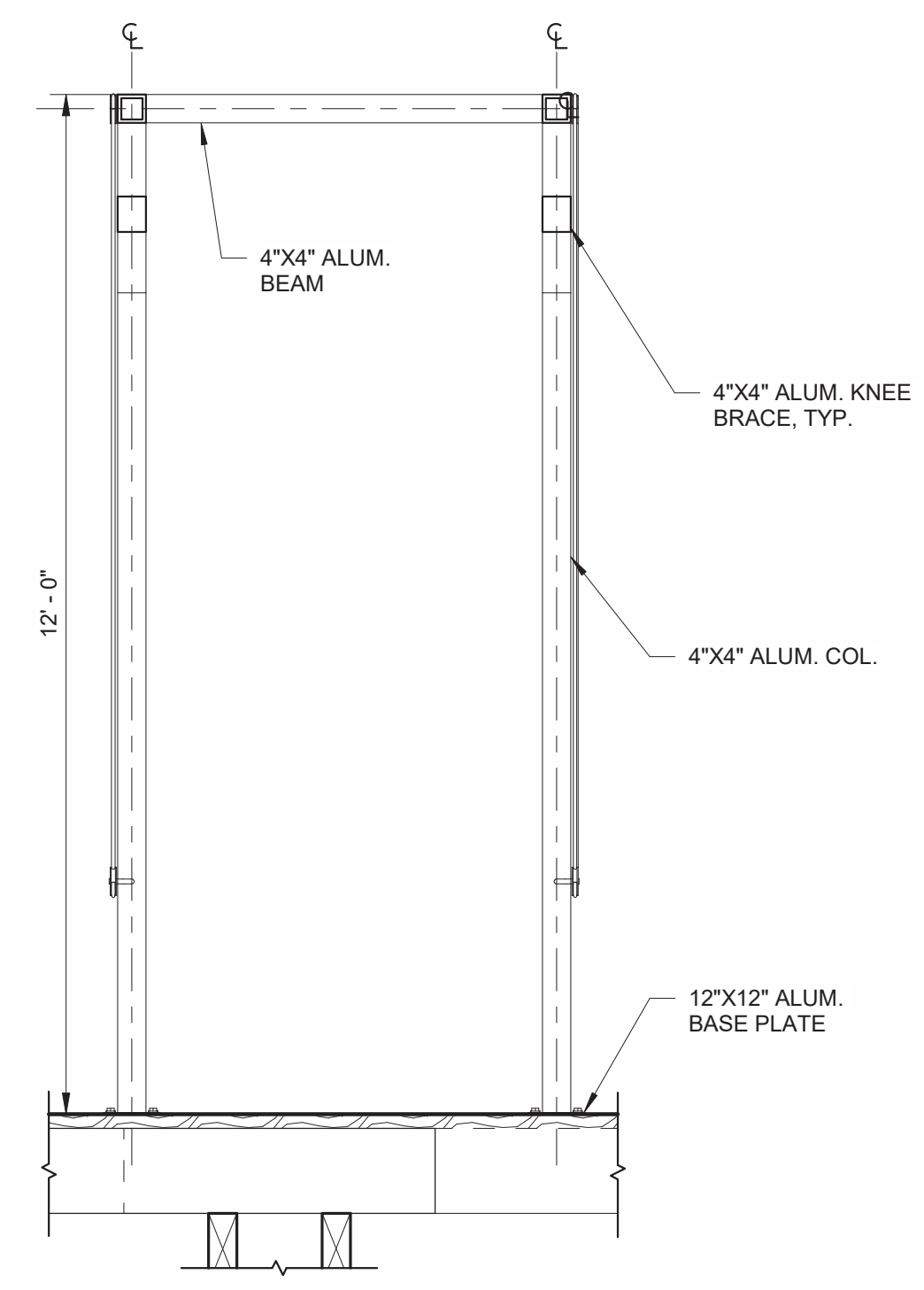

B ENLARGED HOIST FRAME SECTION
M-401 1" = 2'-0"

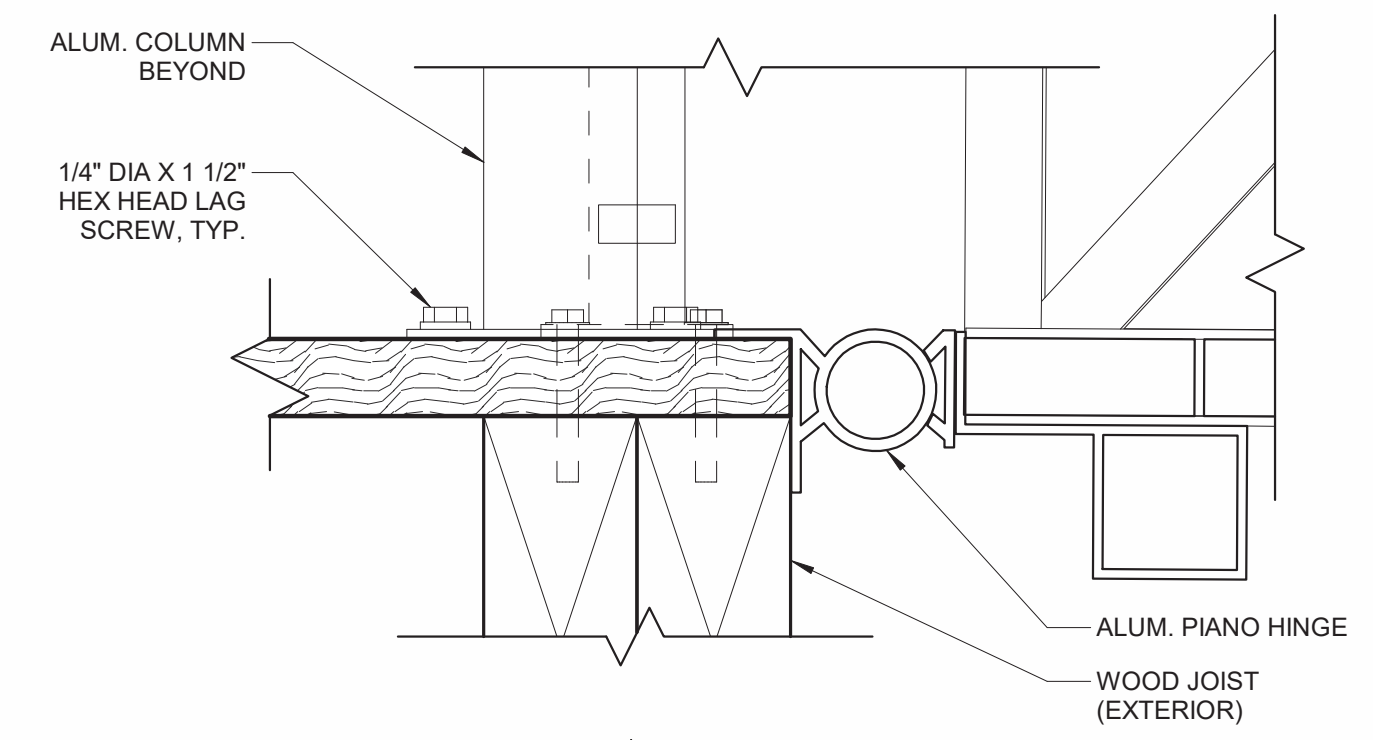

C SECTION
M-401 1" = 0'-5"

Digitally signed by Kristopher P Pagan-Cruz
Date: 2026.02.17 11:20:36-05'00'

MOTT MACDONALD
930 Main Campus Drive, Suite 200
Raleigh, NC 27606
License No. F-0669
T +1 (919) 552 2254
F +1 (919) 552 2254
www.mottmacamericas.com

GRAPHIC SCALE
0 1' 2'
SCALE: 1" = 1'-0"
0 1' 2' 4'
SCALE: 1" = 2'-0"
0 2' 4' 8'
SCALE: 1" = 4'-0"

PROJECT ENGINEER
NORTH CAROLINA PROFESSIONAL SEAL
KRISTOPHER P. PAGAN-CRUZ
044825
ENGINEER

Designed By	JAVIER QUIROS	County	DARE COUNTY
Entered By	VICTOR PADILLA	Division	FERRY DIVISION
Project Engineer	KRISTOPHER PAGAN	Plan Date	1-14-26
Project Manager	ALLISON THORBURN		
Rev.	Date	Drawn	Description
			Ch'k'd
			App'd

NCDOT HATTERAS FERRY DOCK REPLACEMENT

M-401 HOIST FRAME DETAILS

ANSI D (9/9/22)

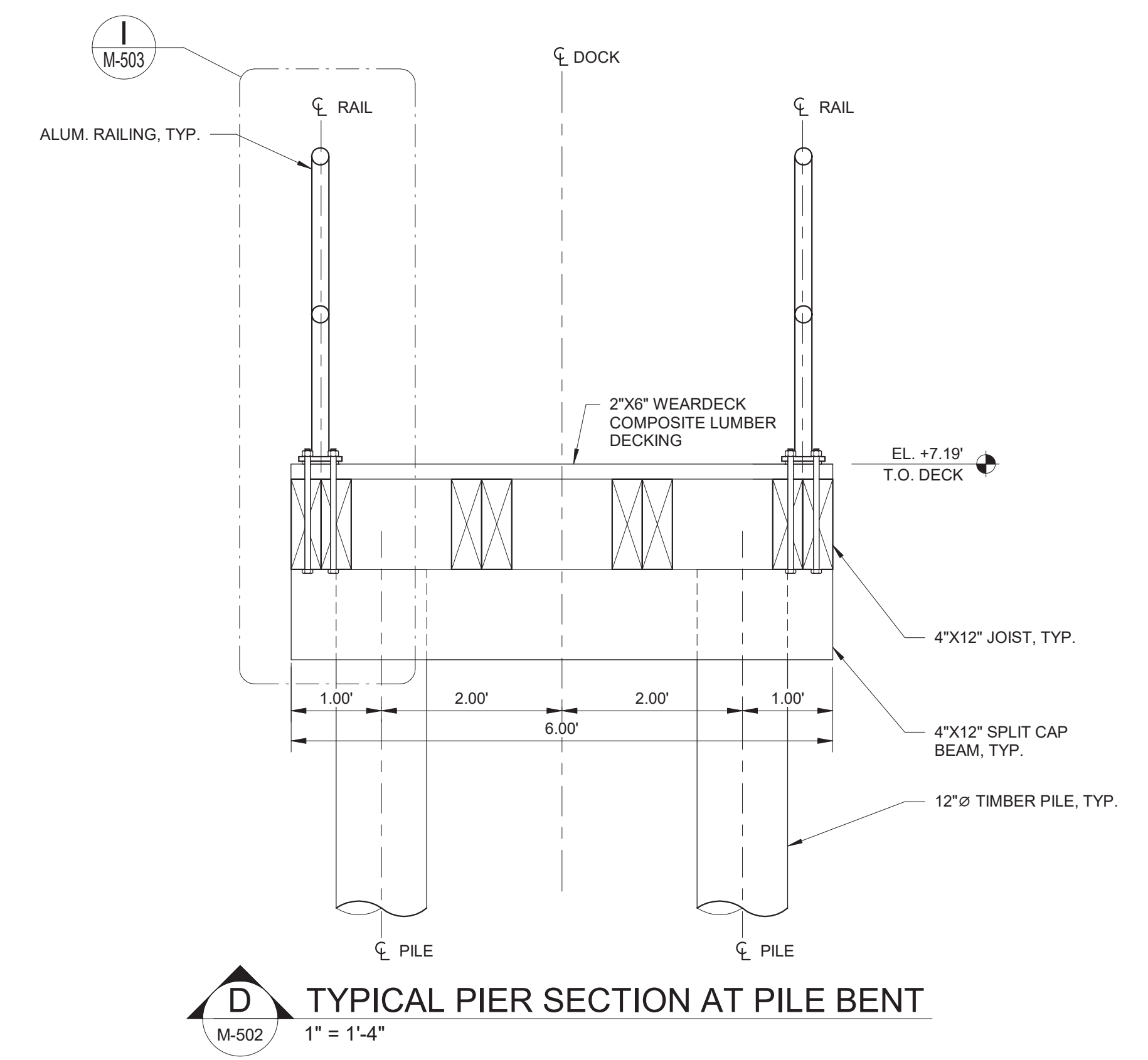
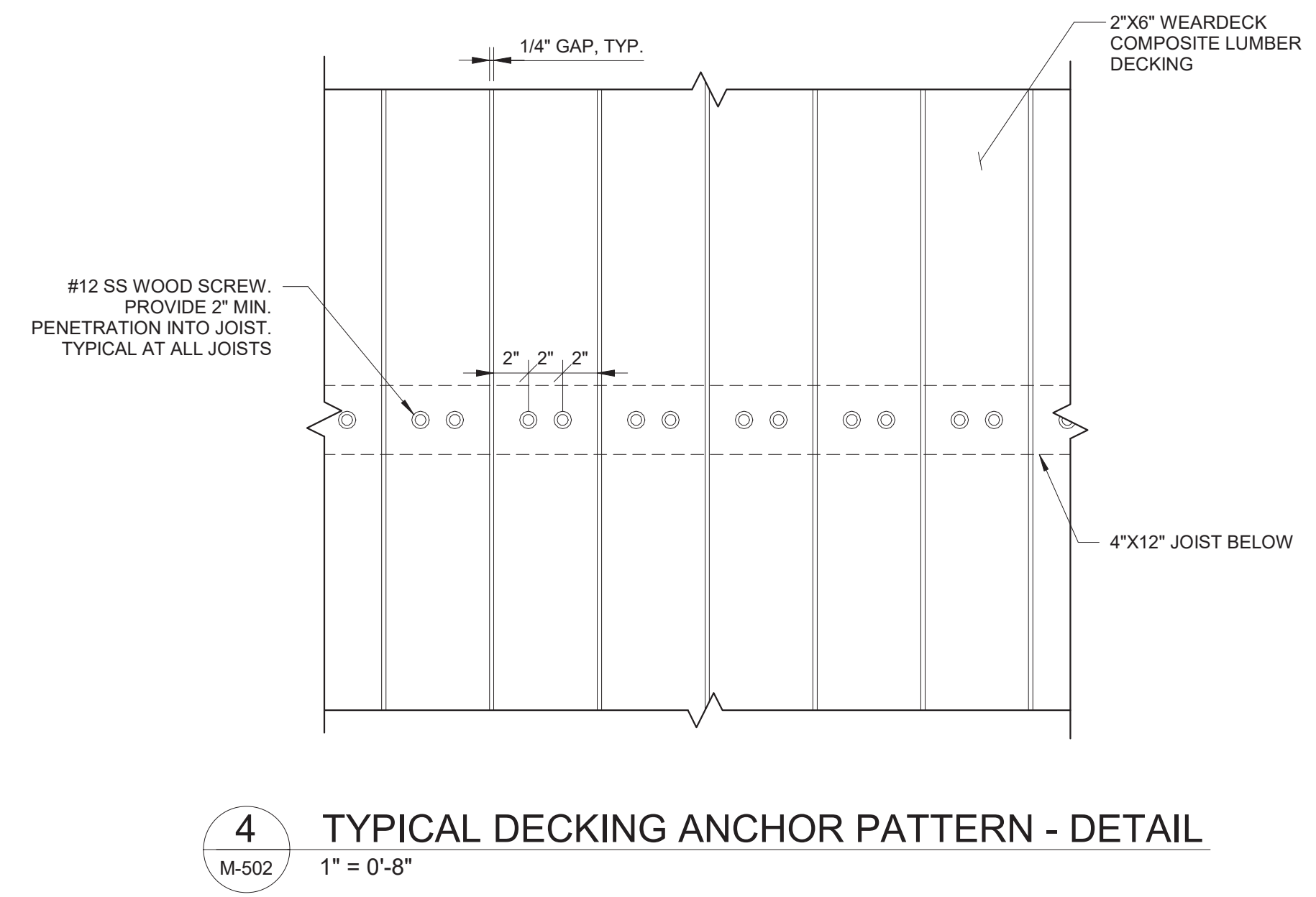
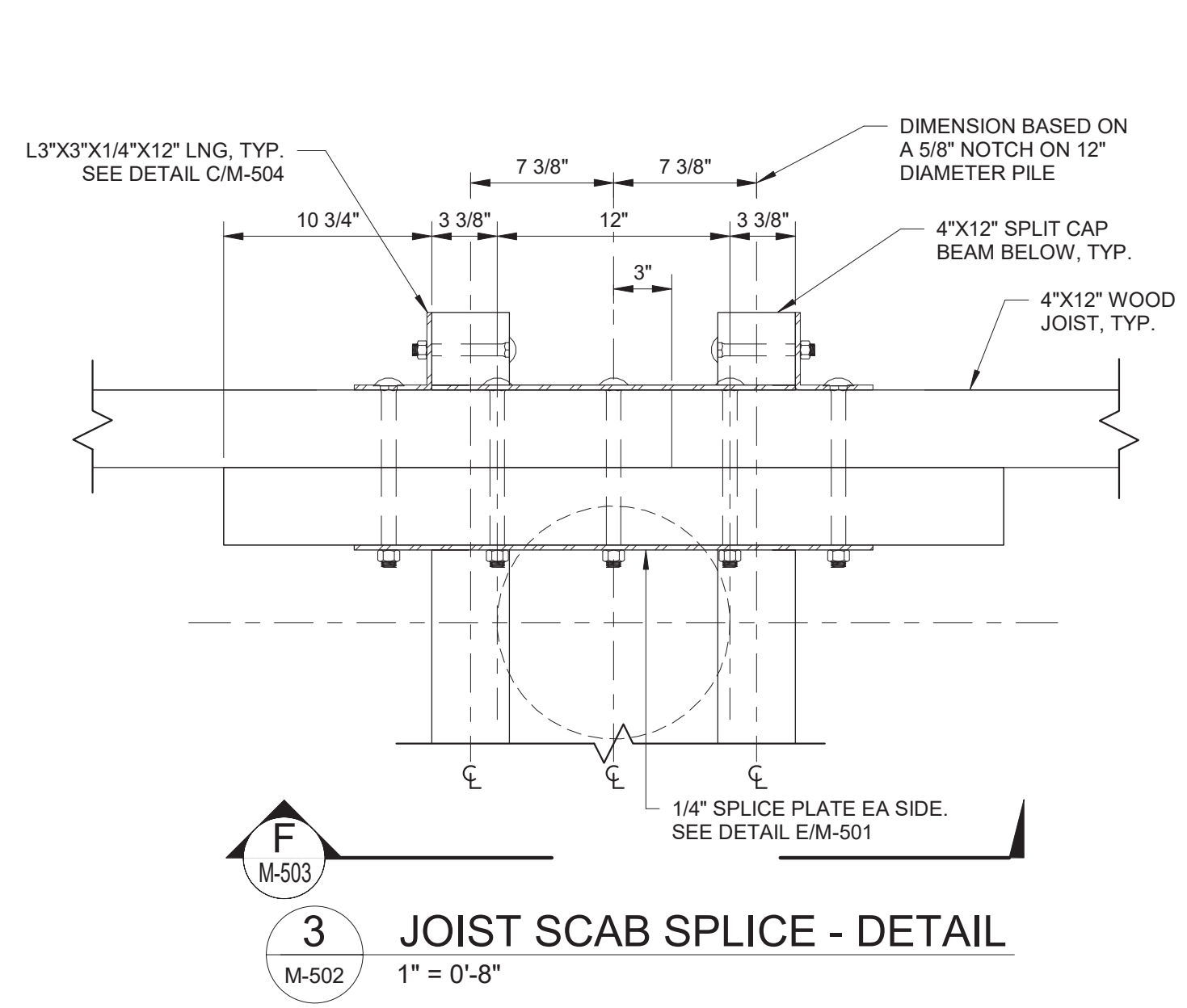
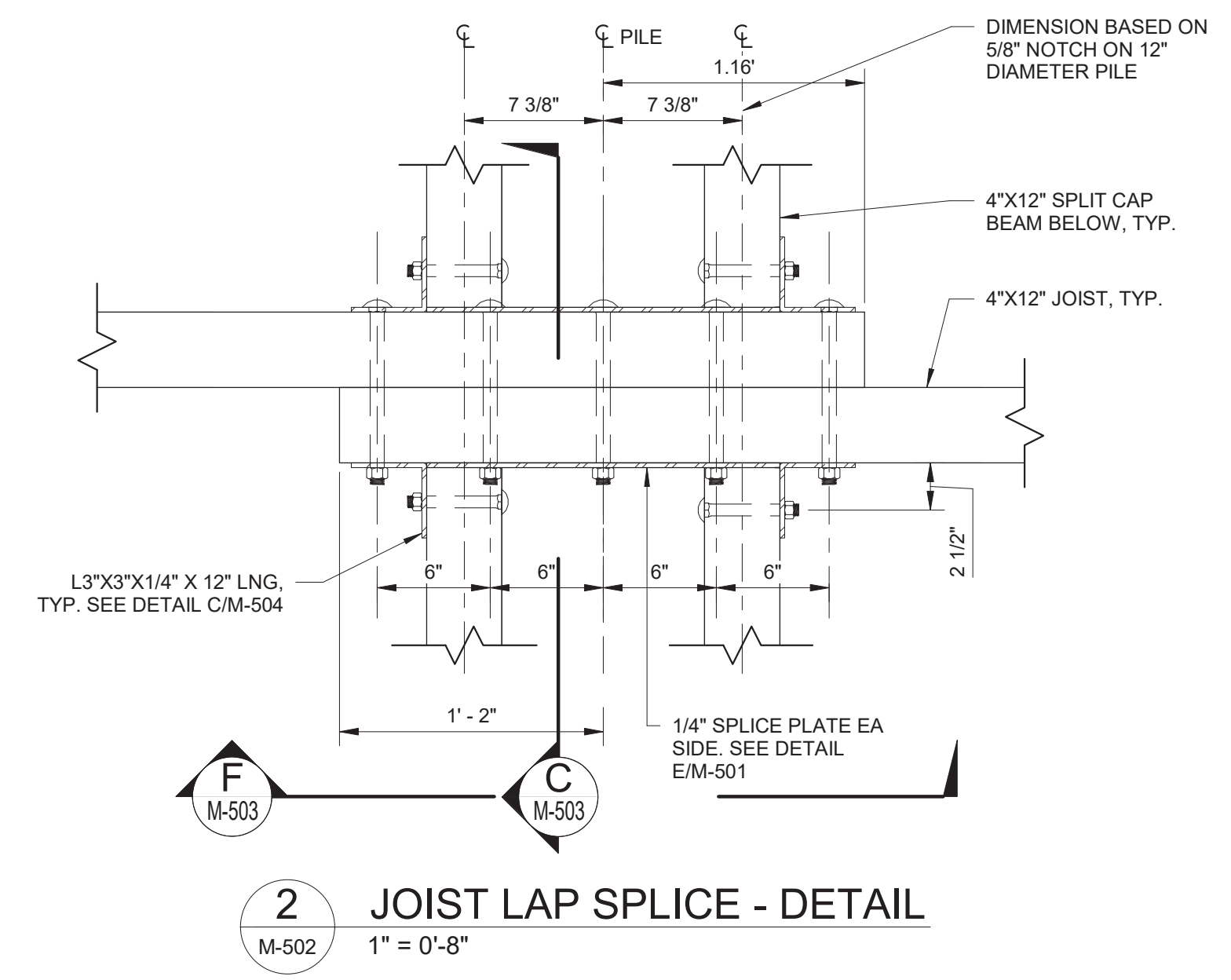
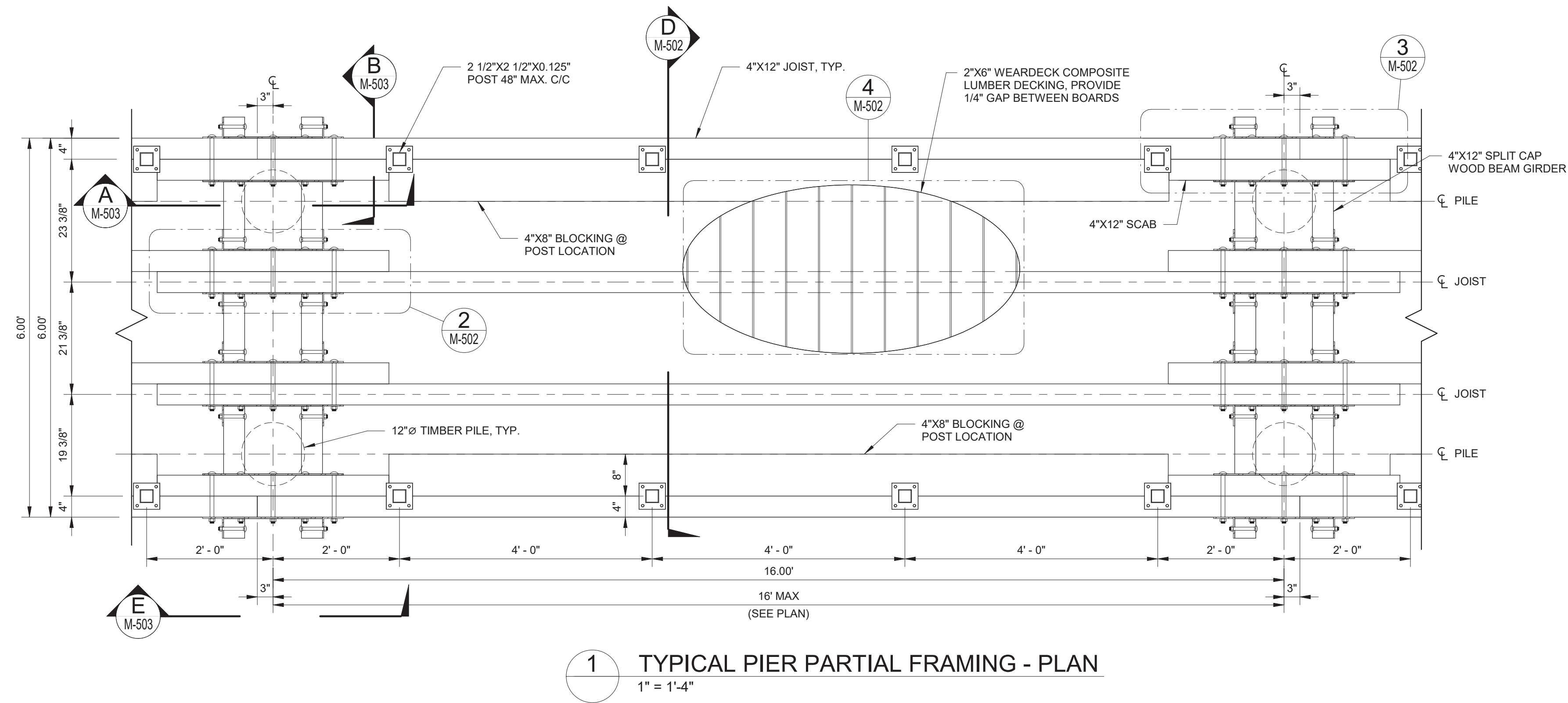

ANSI D (9/21/22)

M M
MOTT MACDONALD
 930 Main Campus Drive,
 Suite 200
 Raleigh, NC 27606
 License No. F-0669
 T +1 (919) 552 2253
 F +1 (919) 552 2254
 www.mottmacamericas.com

GRAPHIC SCALE
 0 0' 1' 1'
 SCALE: 1" = 0'-8"
 0 1' 1' 3'
 SCALE: 1" = 1'-4"

Digitally signed by Kristopher P Pagan-Cruz
 Date: 2026.05.01 16:34:52-04'00'

PROJECT ENGINEER
 KRISTOPHER P. PAGAN-CRUZ
 NORTH CAROLINA
 PROFESSIONAL
 SEAL
 044825
 ENGINEER

Designed By	JAVIER QUIROS	County	DARE COUNTY
Entered By	VICTOR PADILLA	Division	FERRY DIVISION
Project Engineer	KRISTOPHER PAGAN	Plan Date	1-14-26
Project Manager	ALLISON THORBURN		
Rev.	Date	Drawn	Description
			Ch'k'd
			App'd

NCDOT HATTERAS FERRY DOCK REPLACEMENT

M-502 MISCELLANEOUS DETAILS (2 OF 5)

SHEET 14 OF 26

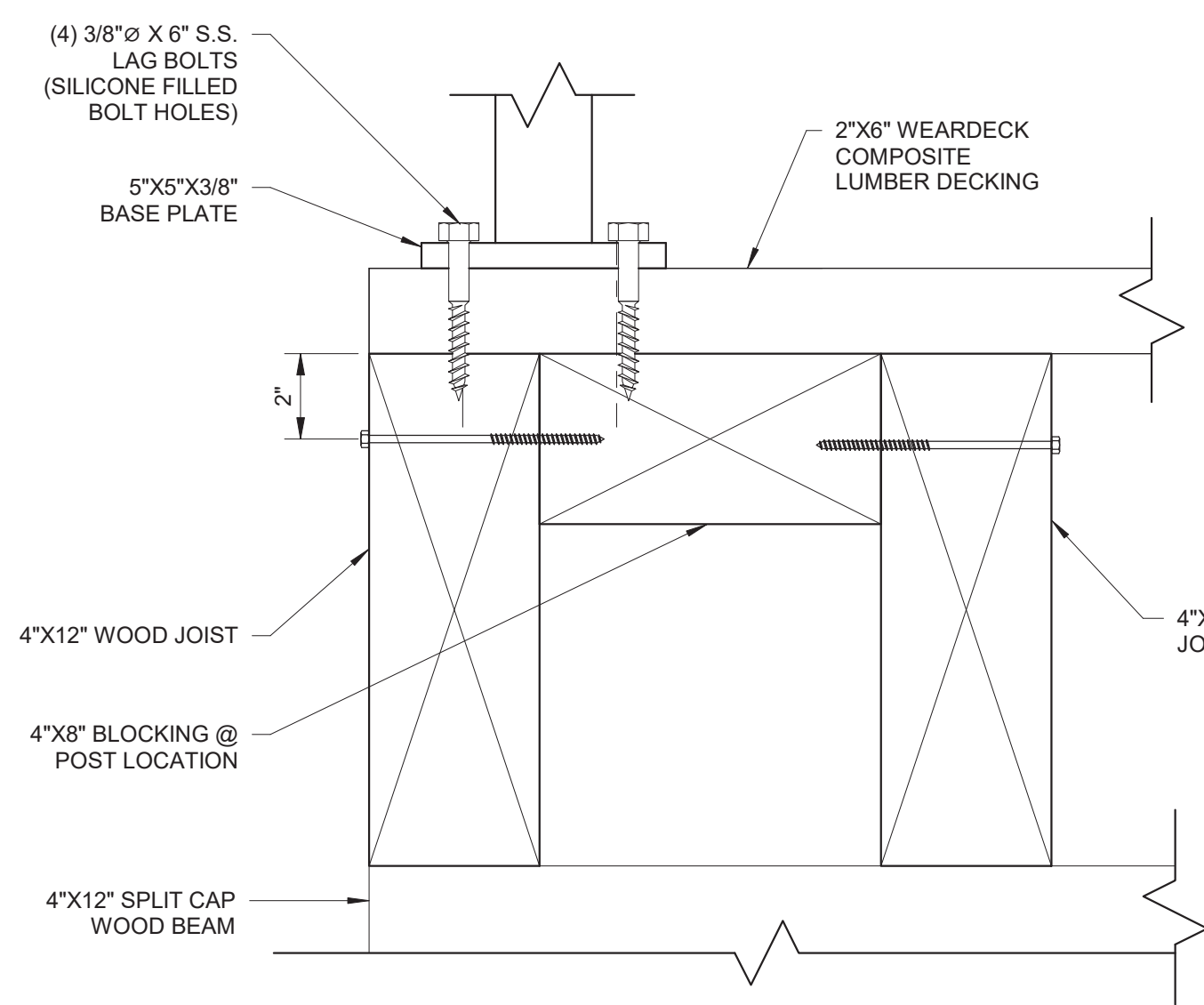

1 TYPICAL DETAIL
M-503 1" = 0'-4"

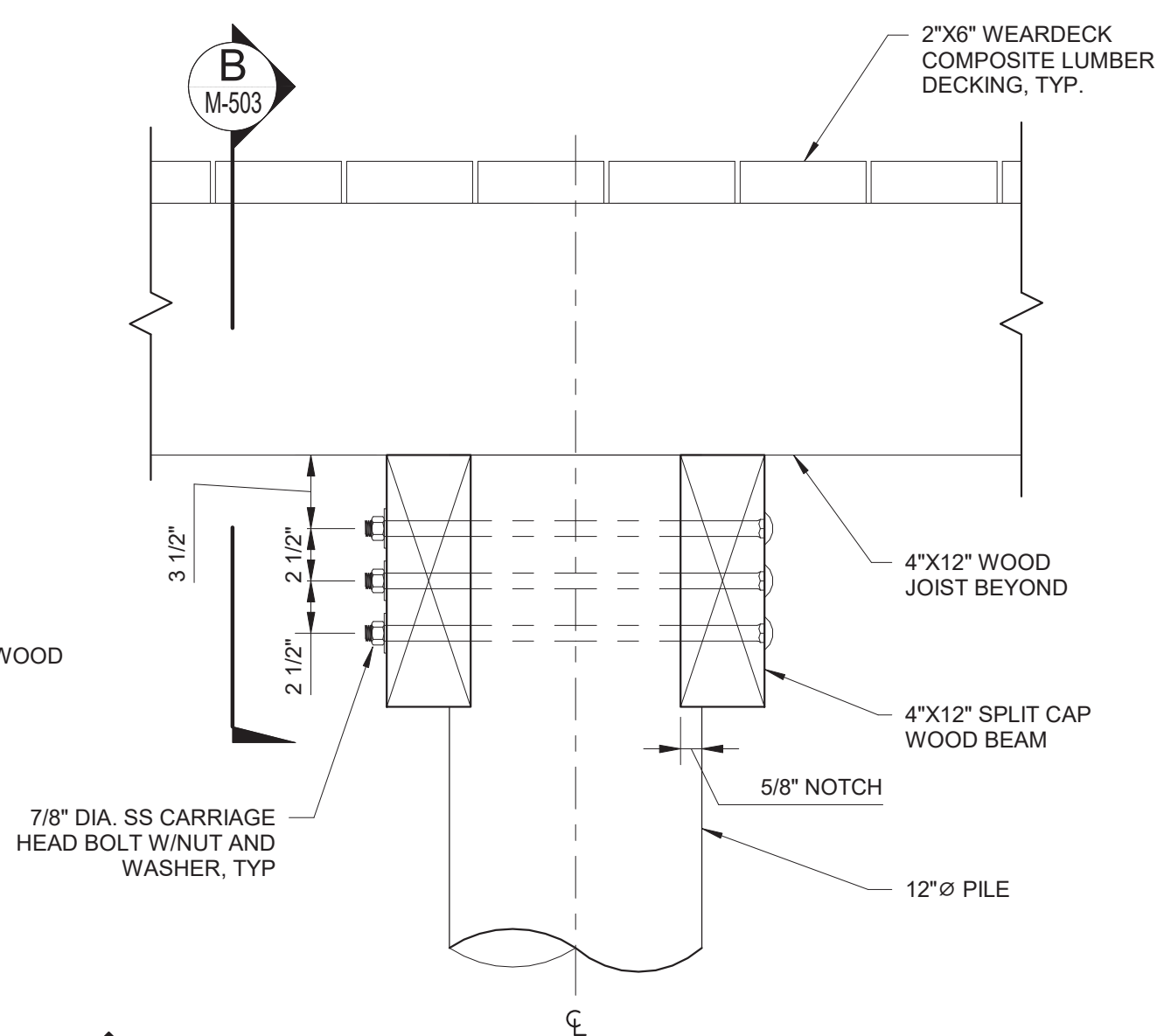

A SPLIT CAP BEAM CONNECTION - SECTION
M-502 1" = 0'-8"

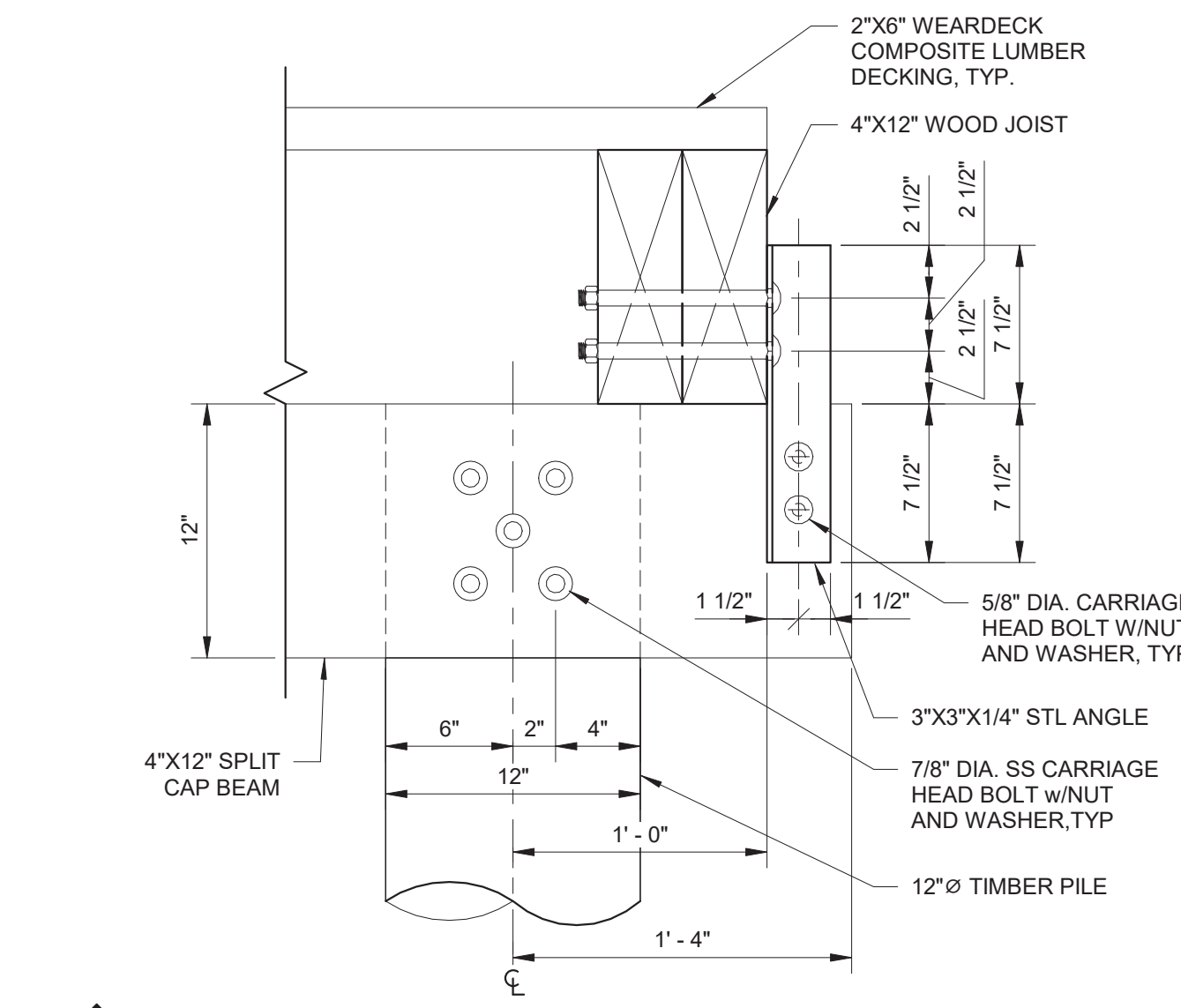

B SPLIT CAP BEAM CONNECTION SIDE VIEW
M-502 1" = 0'-8"

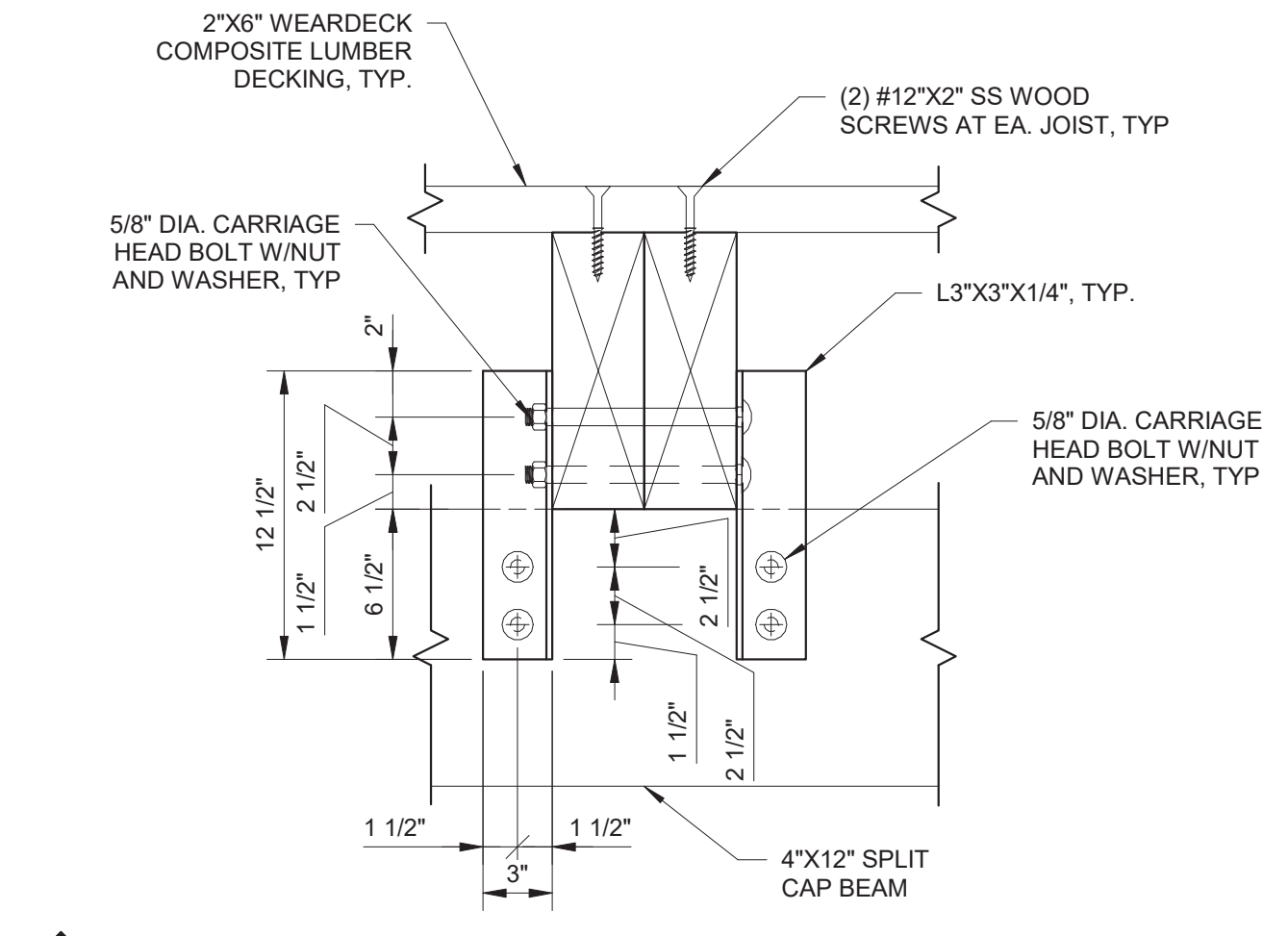

C JOIST LAP SPLICE TO BEAM CONNECTION
M-502 1" = 0'-8"

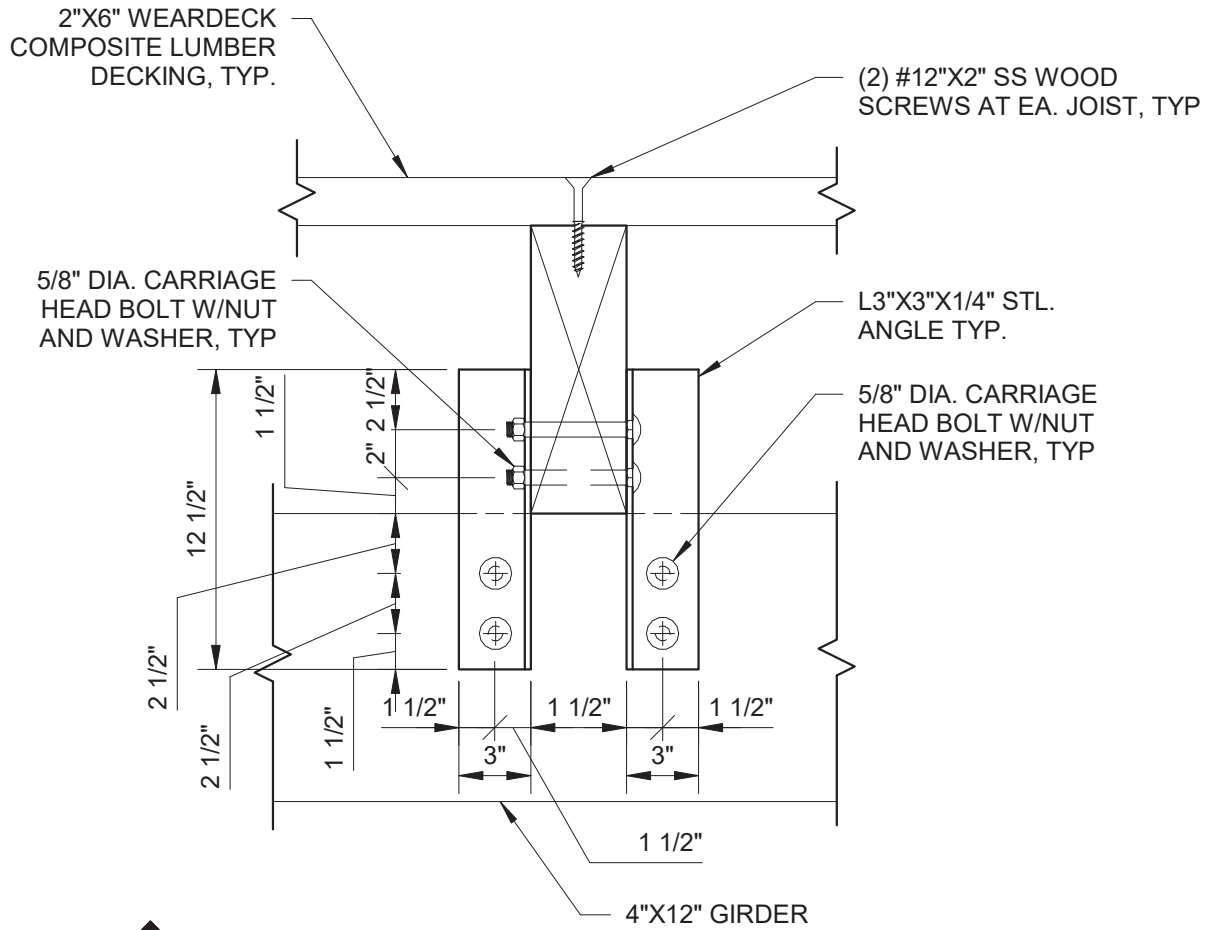

D JOIST TO BEAM CONNECTION
M-503 1" = 0'-8"

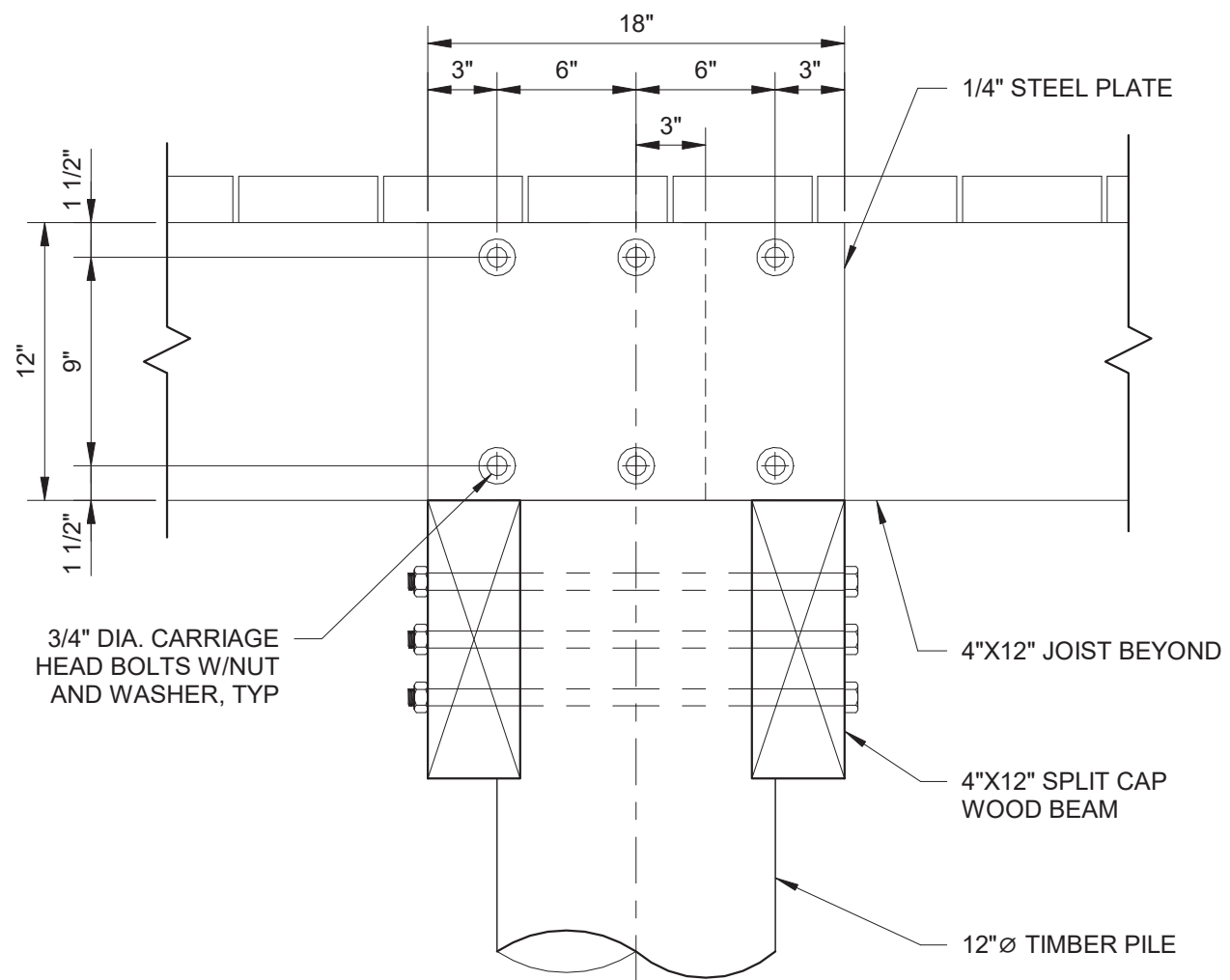

E SCAB SPLICE - SECTION
M-502 1" = 0'-8"

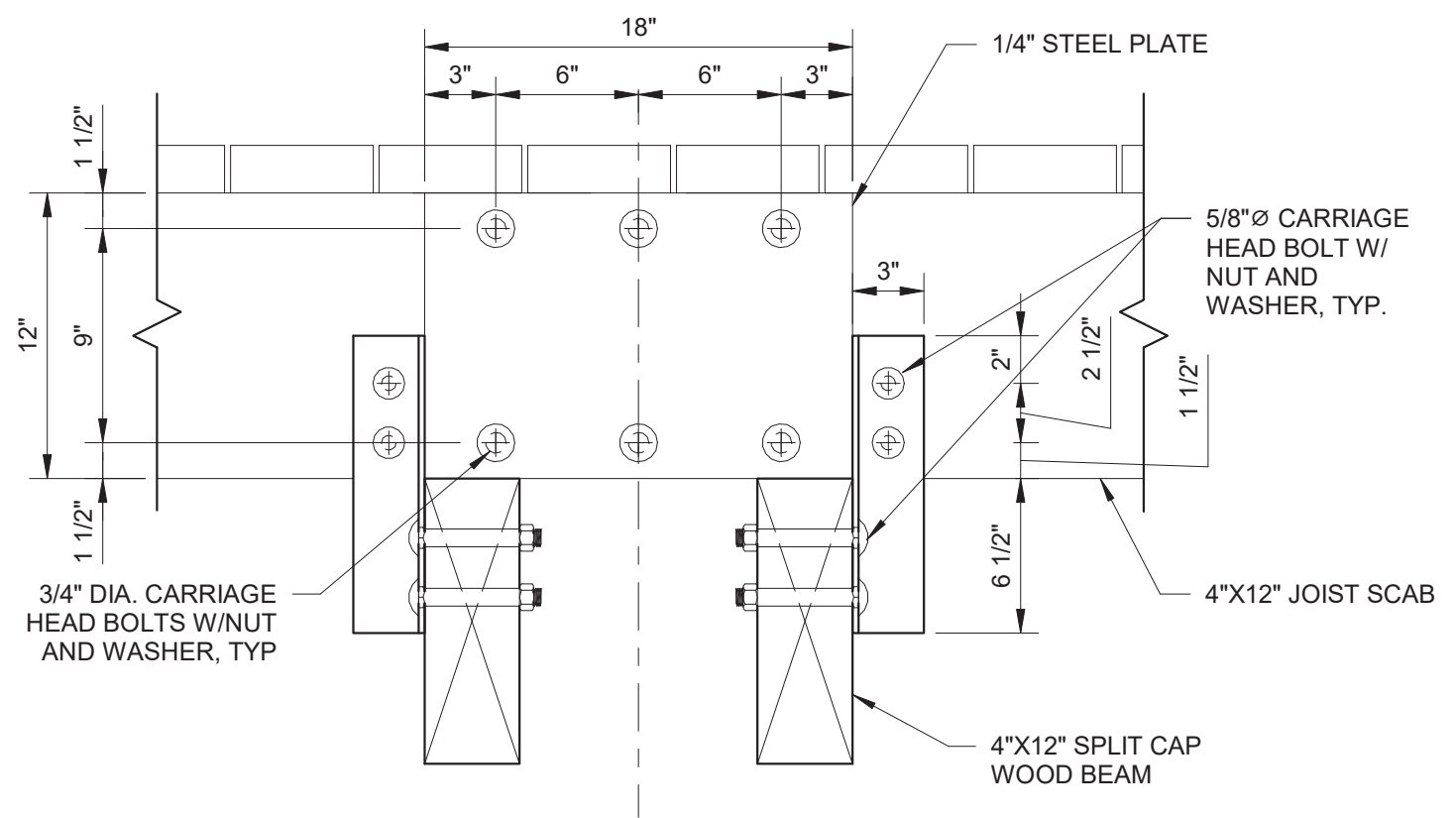

F LAP SPLICE - SECTION
M-502 1" = 0'-8"

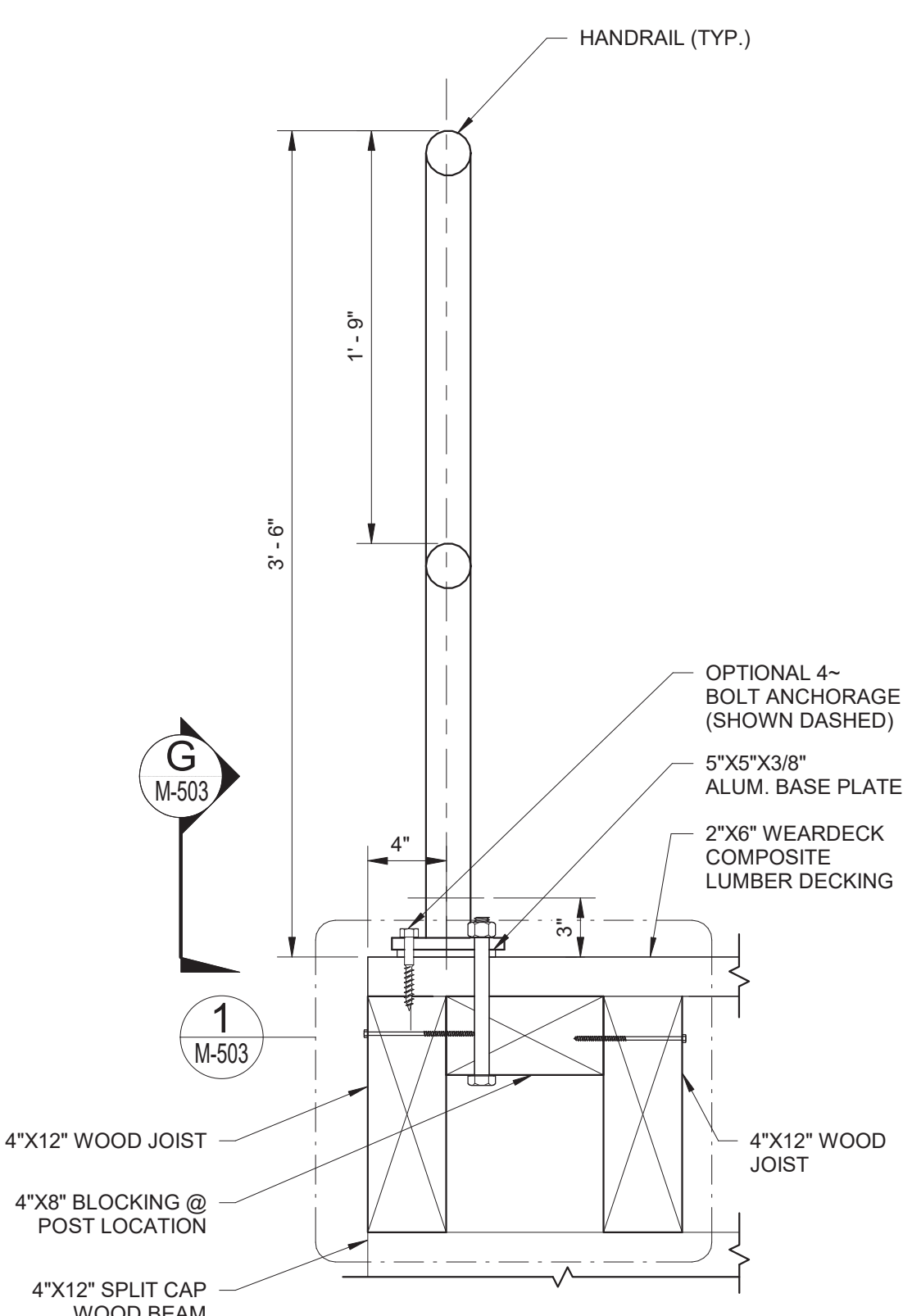

I TYPICAL RAILING - SECTION
M-502 1" = 0'-8"

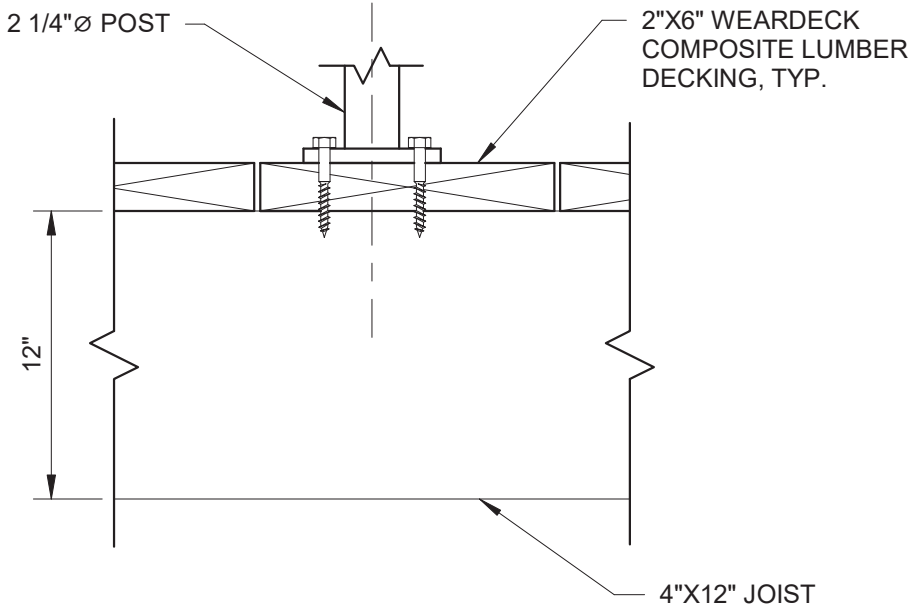

G GUARD RAILING POST CONNECTION - SECTION
M-503 1" = 0'-8"

ANSI D (34x22)

M M
MOTT MACDONALD
930 Main Campus Drive,
Suite 200
Raleigh, NC 27606
License No. F-0669
T +1 (919) 552 2253
F +1 (919) 552 2254
www.mottmacamericas.com

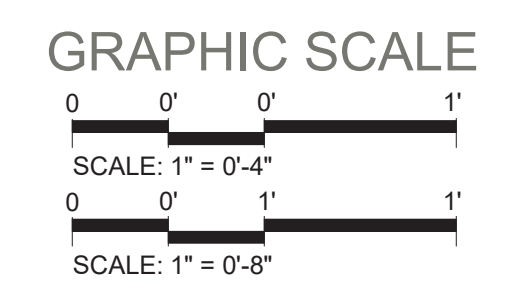

Digitally signed by Kristopher P Pagan-Cruz
Date: 2026.05.01 16:35:20-04'00'

Rev.	Date	Drawn	Description	Ch'kd	App'd

NCDOT HATTERAS FERRY DOCK REPLACEMENT

M-503 MISCELLANEOUS DETAILS (3 OF 5)

04/08/26

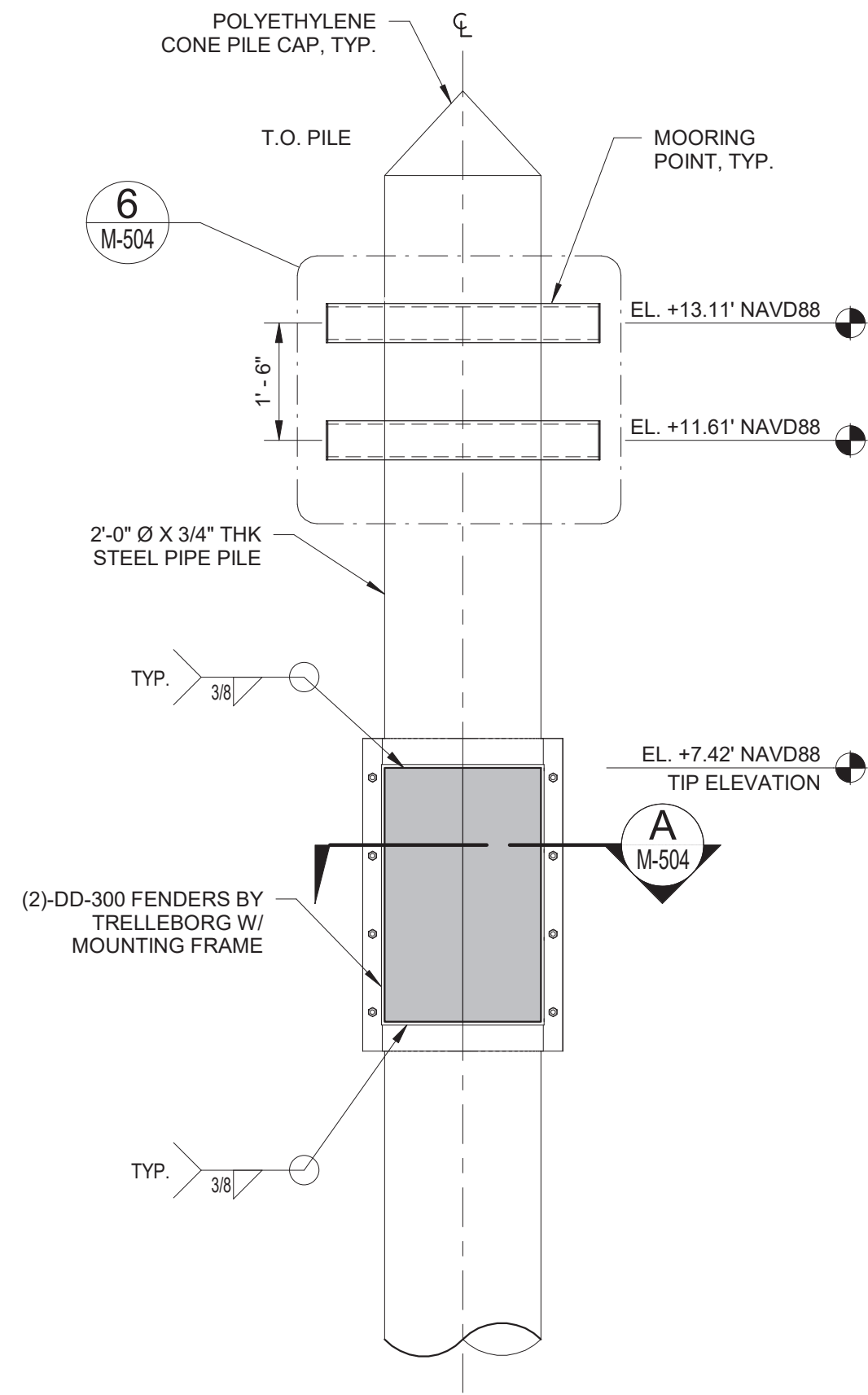

1 FENDER PILE FRONT - VIEW
1" = 2'-0"

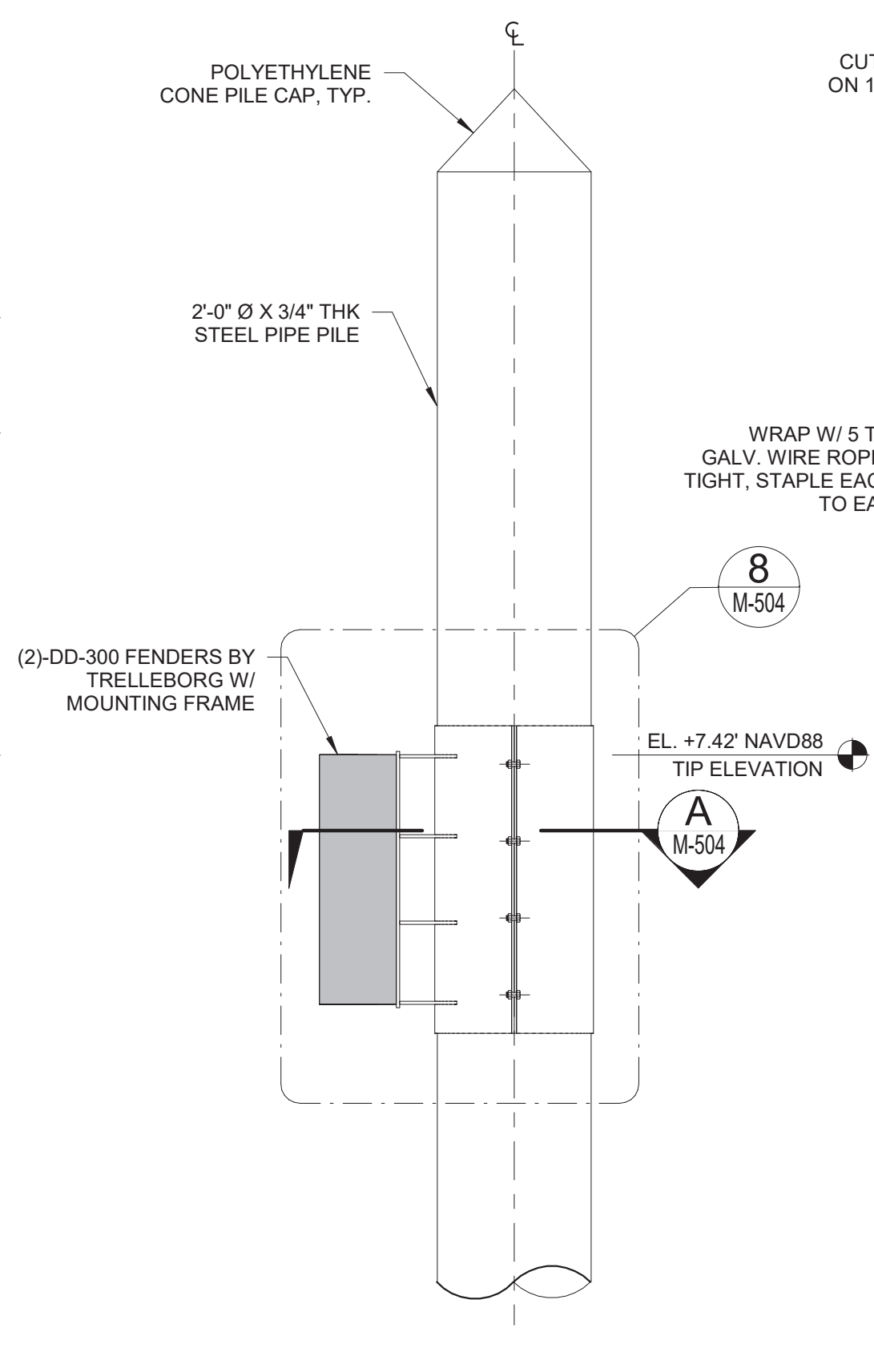

2 FENDER PILE LATERAL - VIEW
1" = 2'-0"

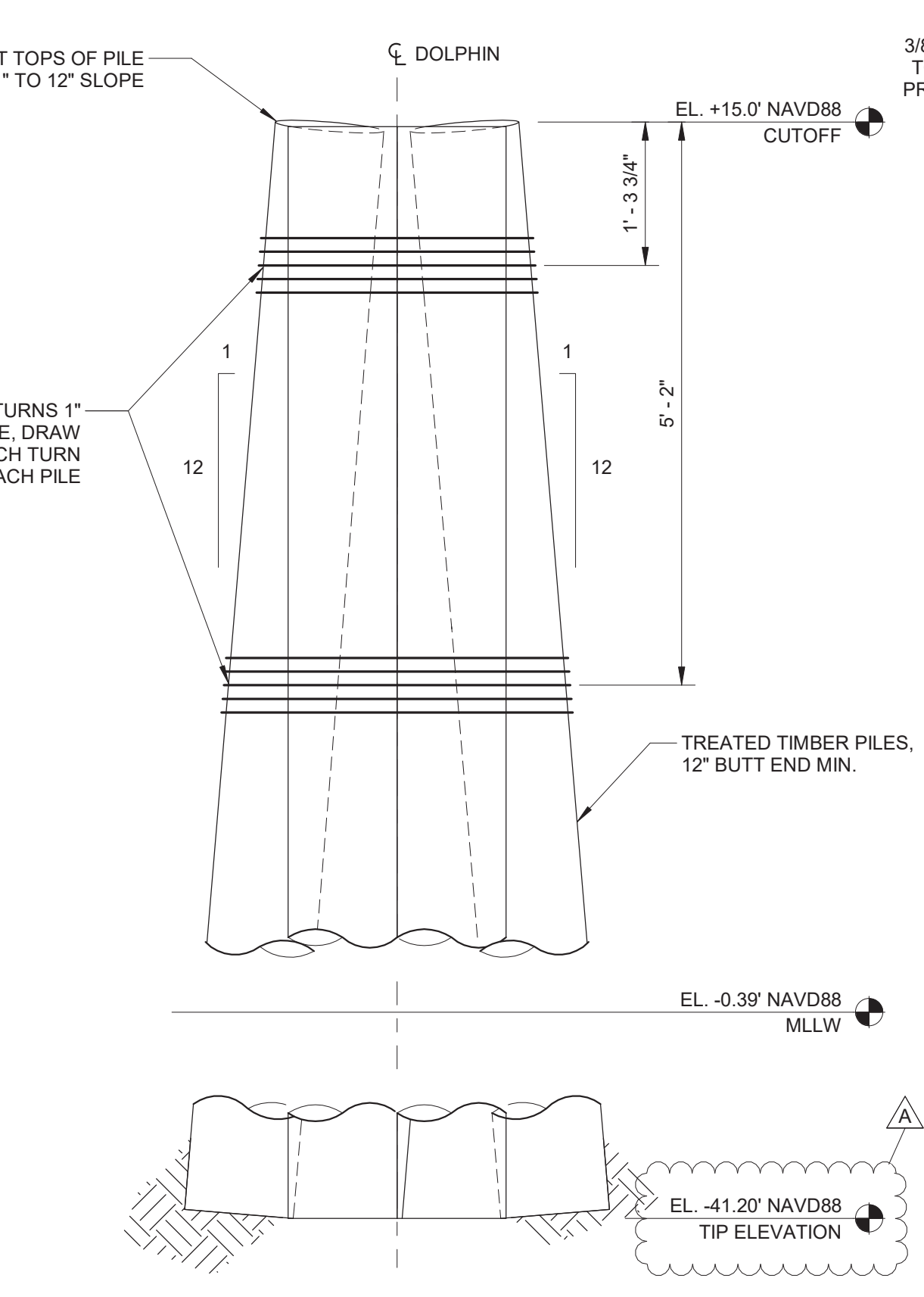

3 4 PILES DOLPHIN - ELEVATION
1" = 1'-4"

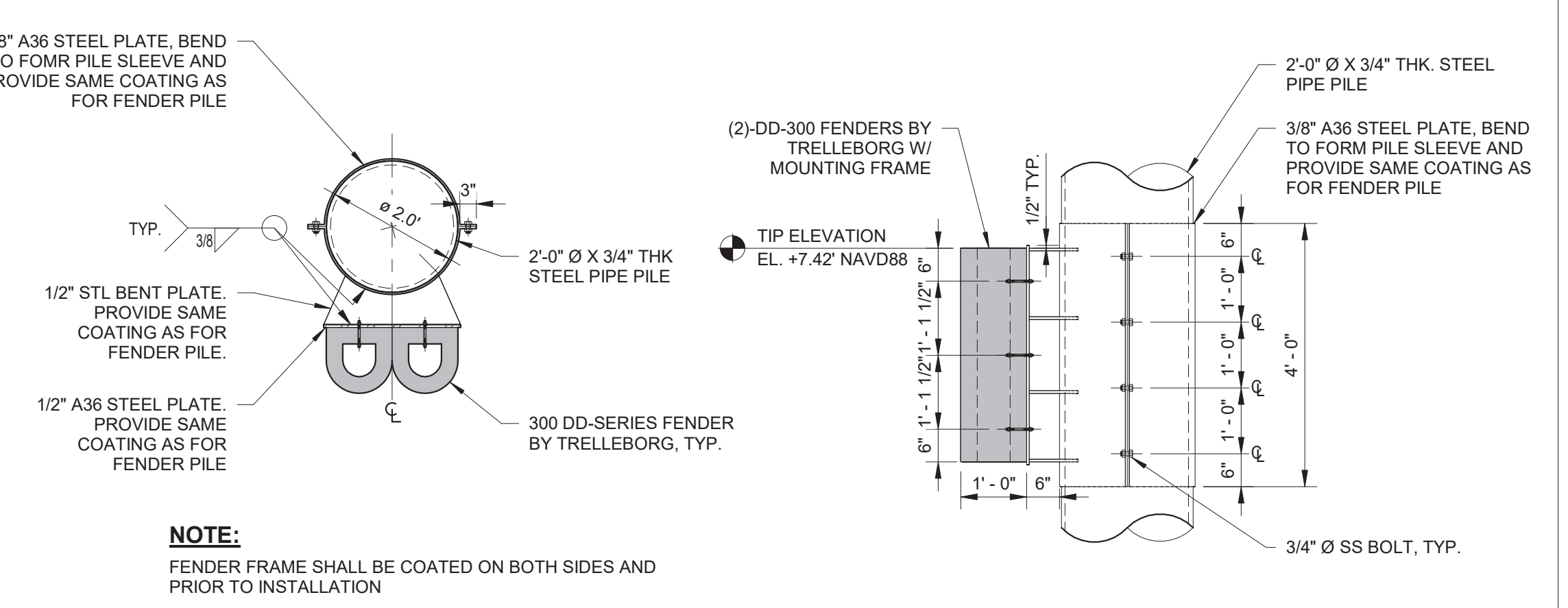

A M-504 FENDER FRAME - SECTION
1" = 2'-0"

8 M-504 FENDER FRAME - DETAIL
1/2" = 1'-0"

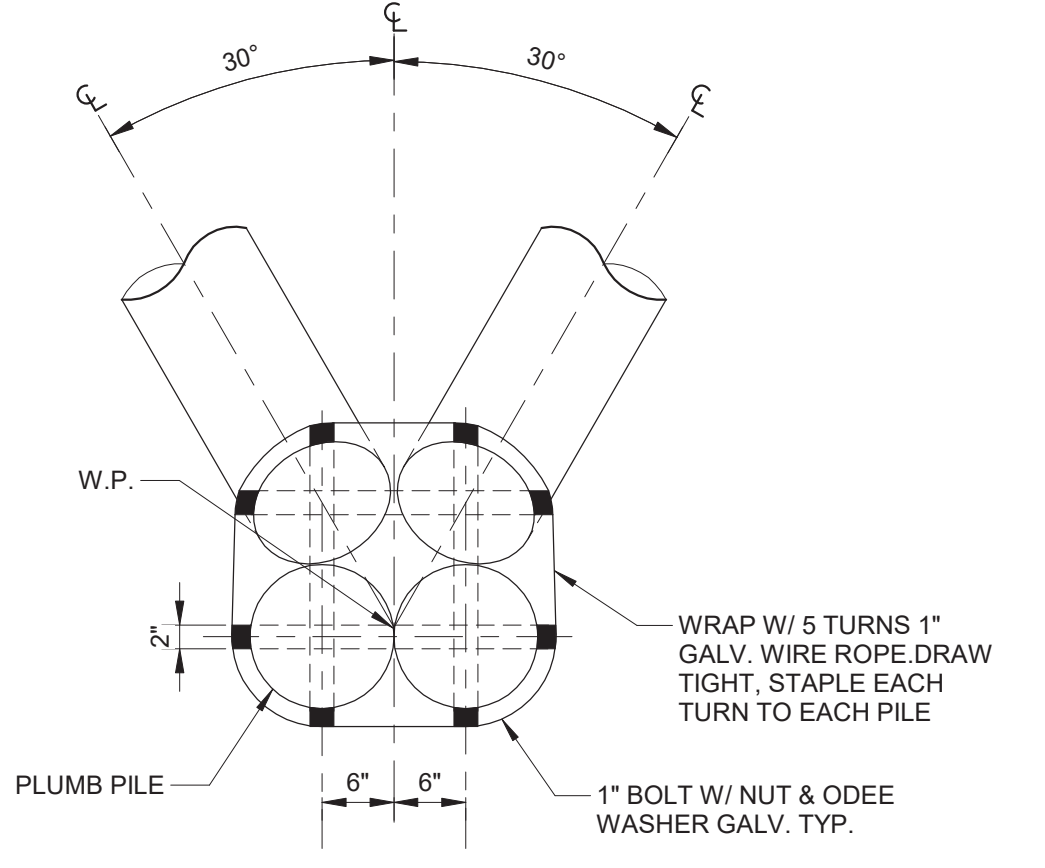

4 M-504 4 PILES DOLPHIN - PLAN
1" = 1'-4"

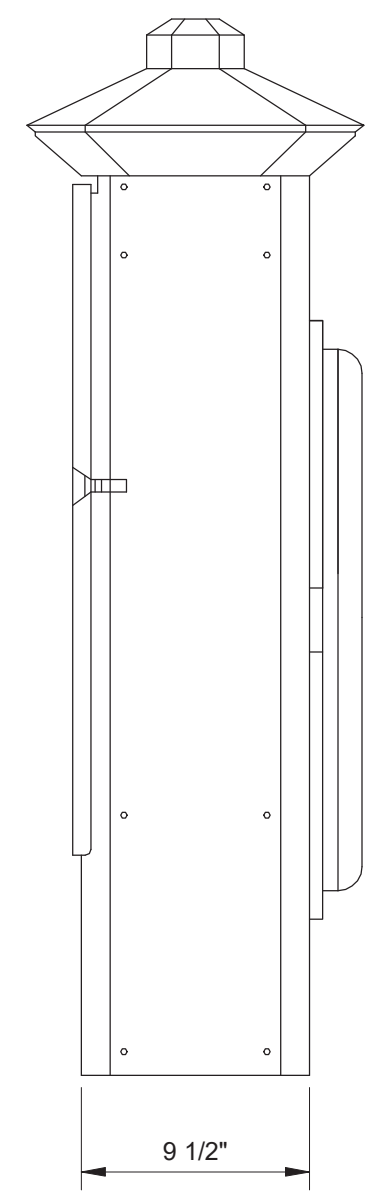

SIDE VIEW

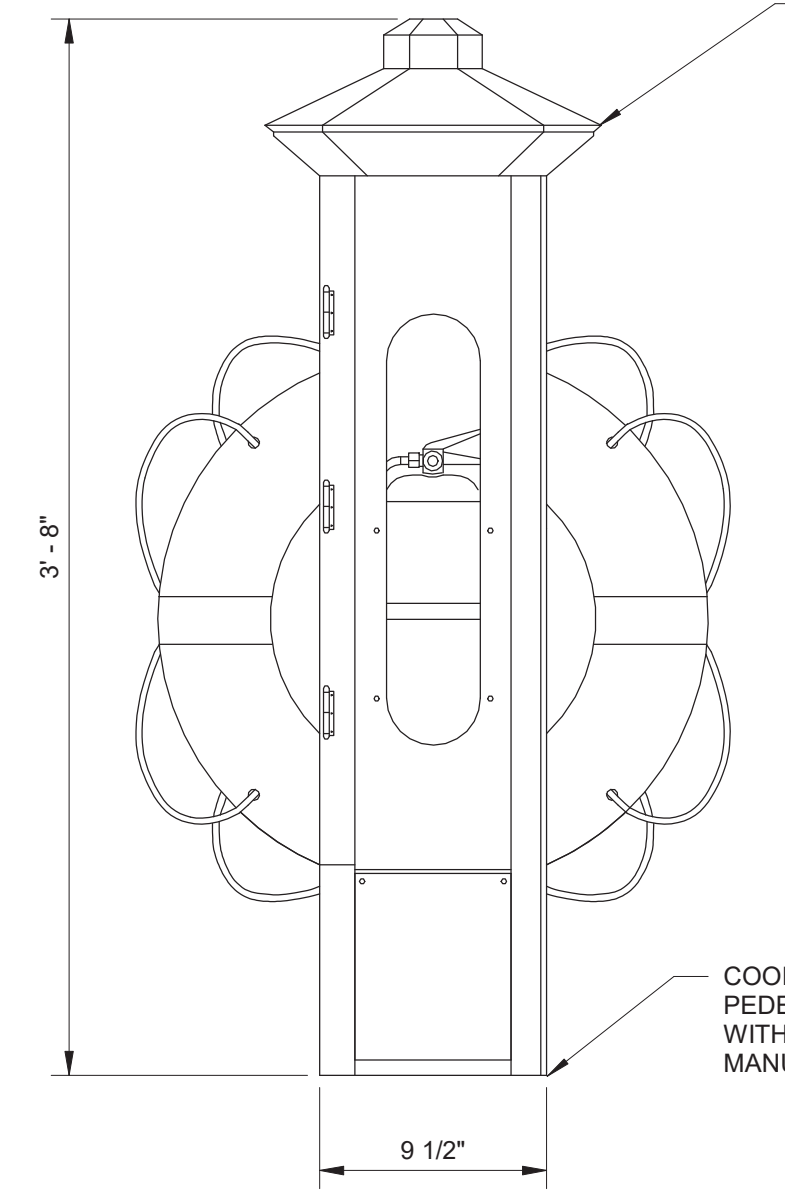

FRONT VIEW

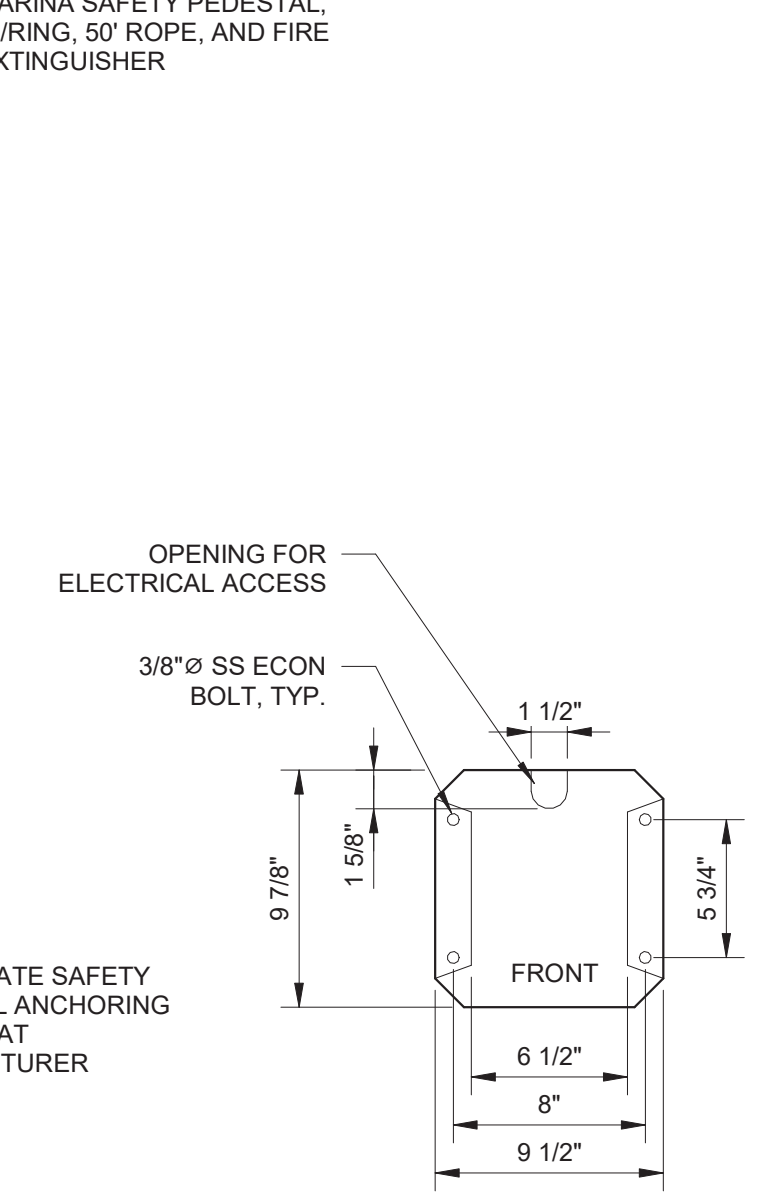

BASE PLATE

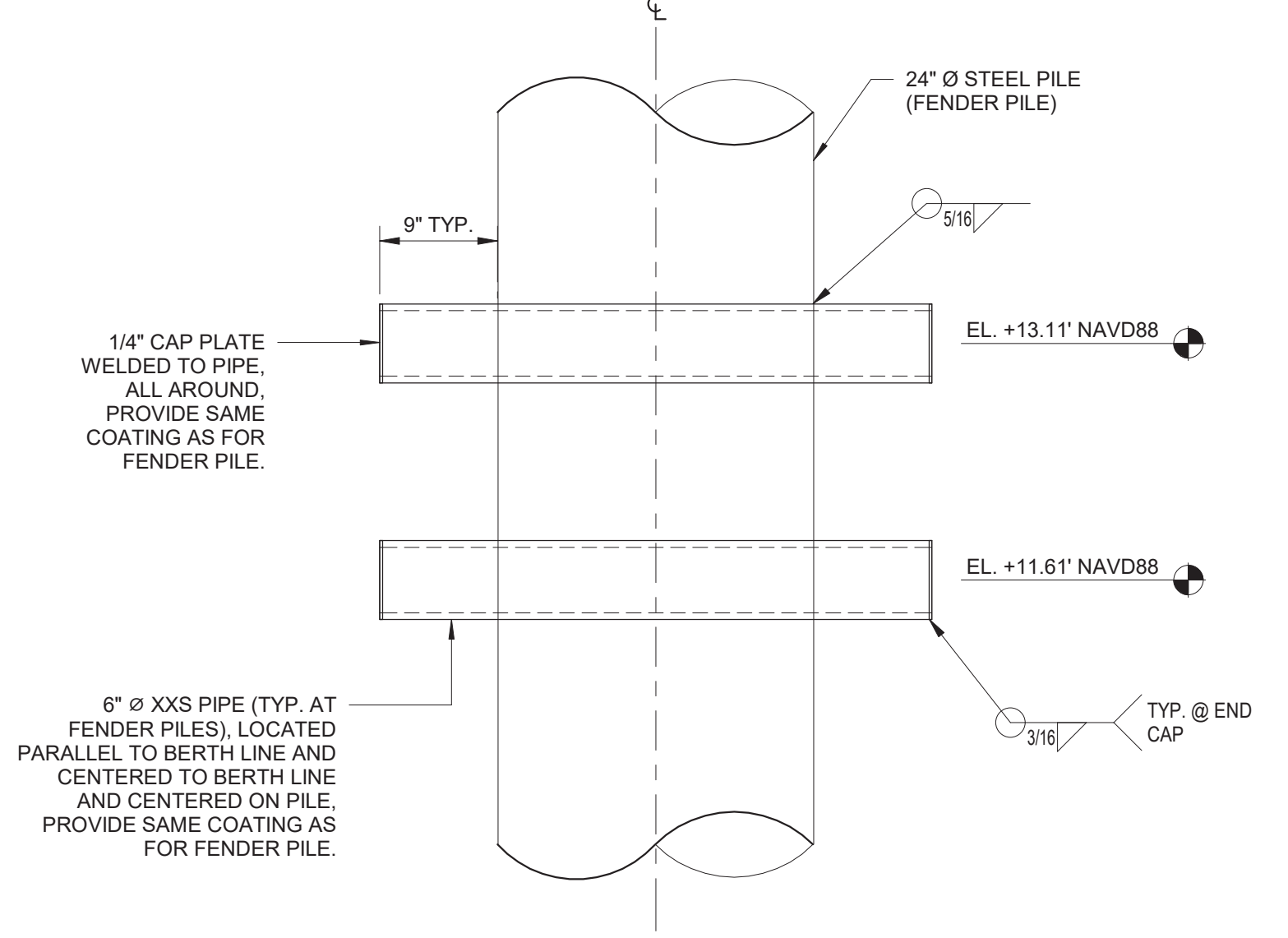

6 M-504 FENDER PILE MOORING - DETAIL
1" = 1'-0"

5 SAFETY PEDESTAL - DETAIL
1" = 0'-8"

MOTT MACDONALD
930 Main Campus Drive, Suite 200
Raleigh, NC 27606
License No. F-0669
T +1 (919) 552 2253
F +1 (919) 552 2254
www.mottmacamericas.com

GRAPHIC SCALE
0 0' 1' 1'
SCALE: 1" = 0'-8"
0 1' 1' 2'
SCALE: 1" = 1'-0"
0 1' 1' 3'
SCALE: 1" = 1'-4"

PROJECT ENGINEER
NORTH CAROLINA PROFESSIONAL SEAL
KRISTOPHER PAGAN
044825
ENGINEER
KRISTOPHER PAGAN

Designed By	JAVIER QUIROS	County	DARE COUNTY
Entered By	VICTOR PADILLA	Division	FERRY DIVISION
Project Engineer	KRISTOPHER PAGAN	Plan Date	1-14-26
Project Manager	ALLISON THORBURN		
Rev.	Date	Drawn	Description
A	04/08/26	VP	BID CLARIFICATIONS
			JQ KP
			Ch'kd App'd

NCDOT HATTERAS FERRY DOCK REPLACEMENT
M-504 MISCELLANEOUS DETAILS (4 OF 5)

ANSI D (94°x22°)

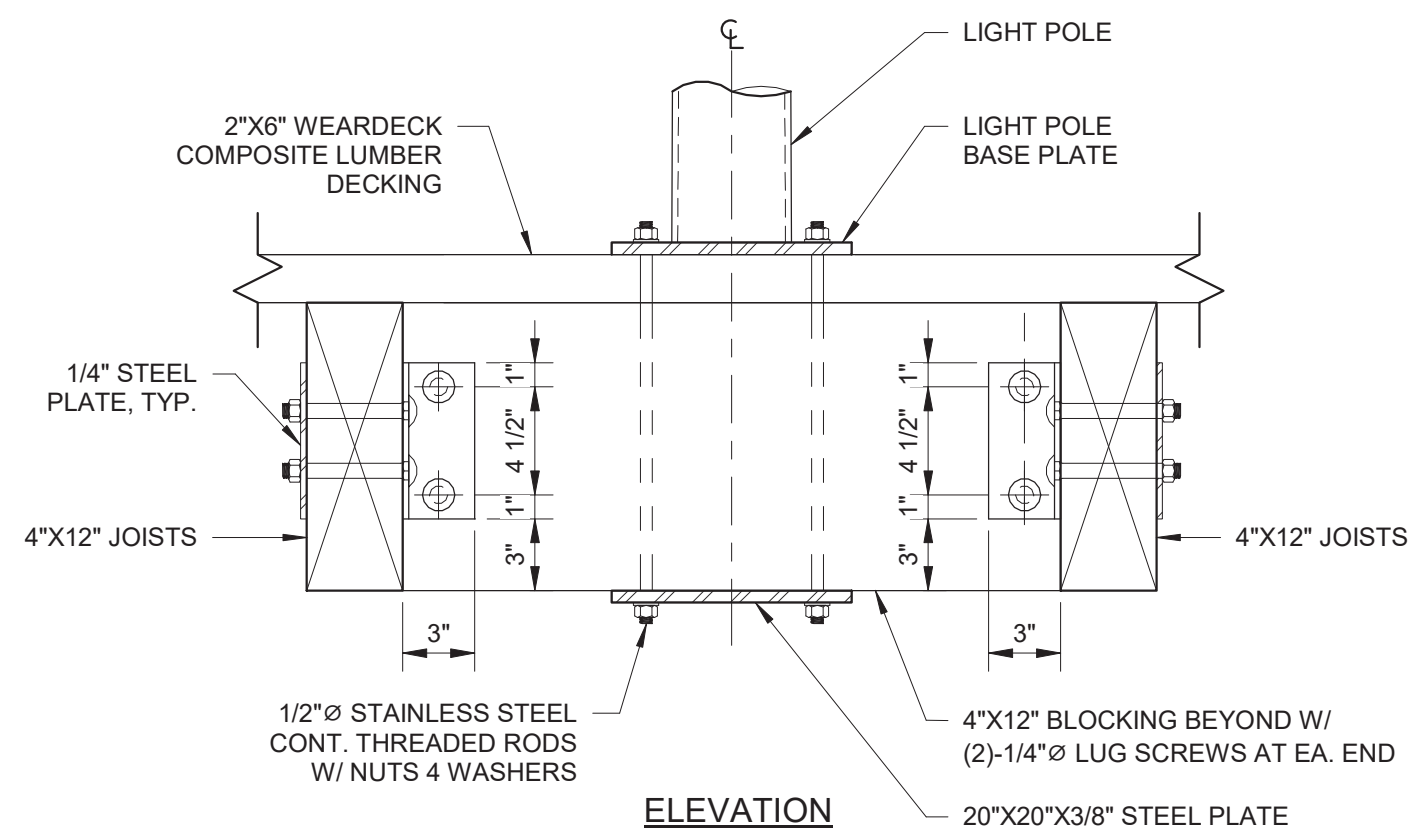
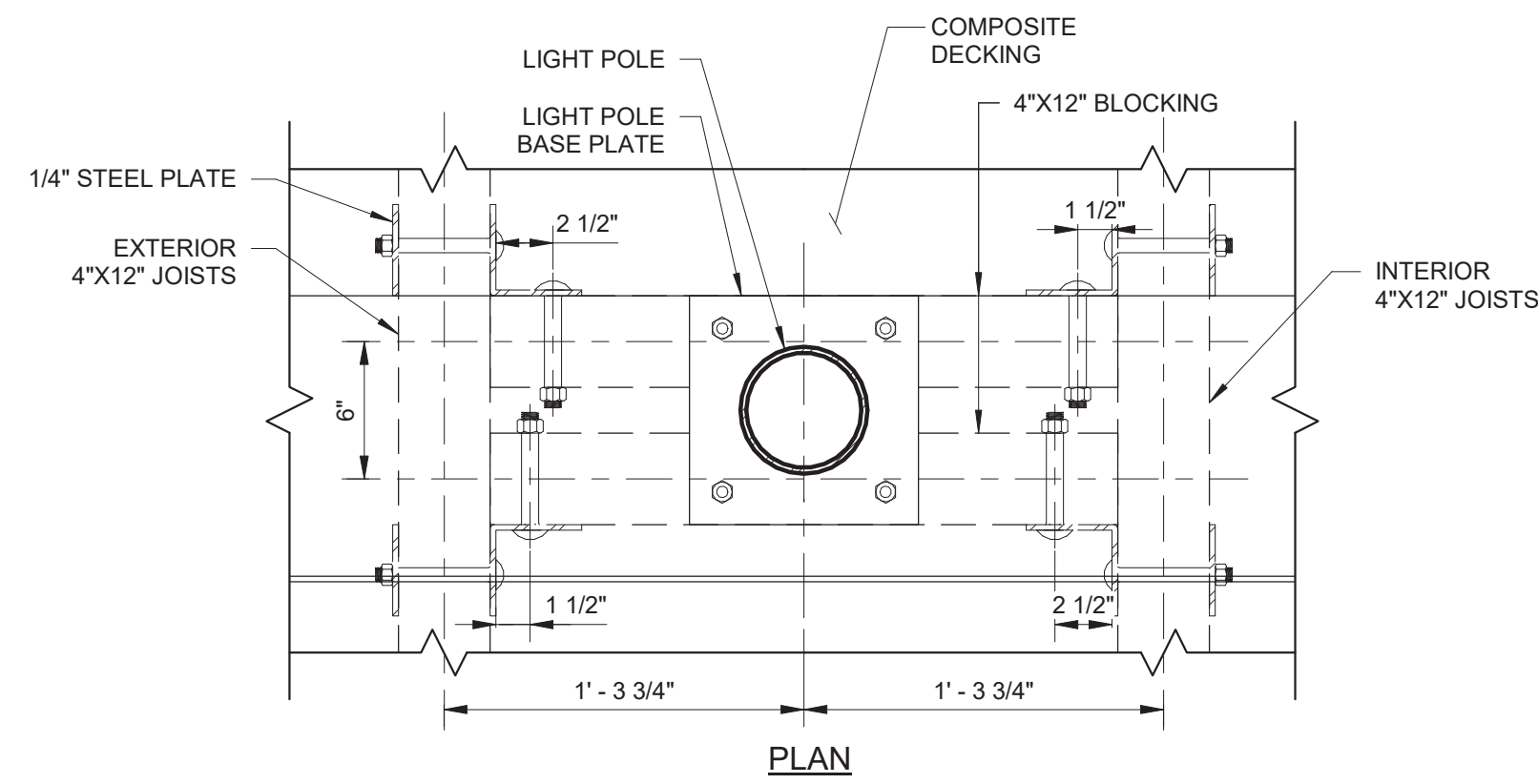

1 LIGHT POLE - DETAIL
1 1/2" = 1'-0"

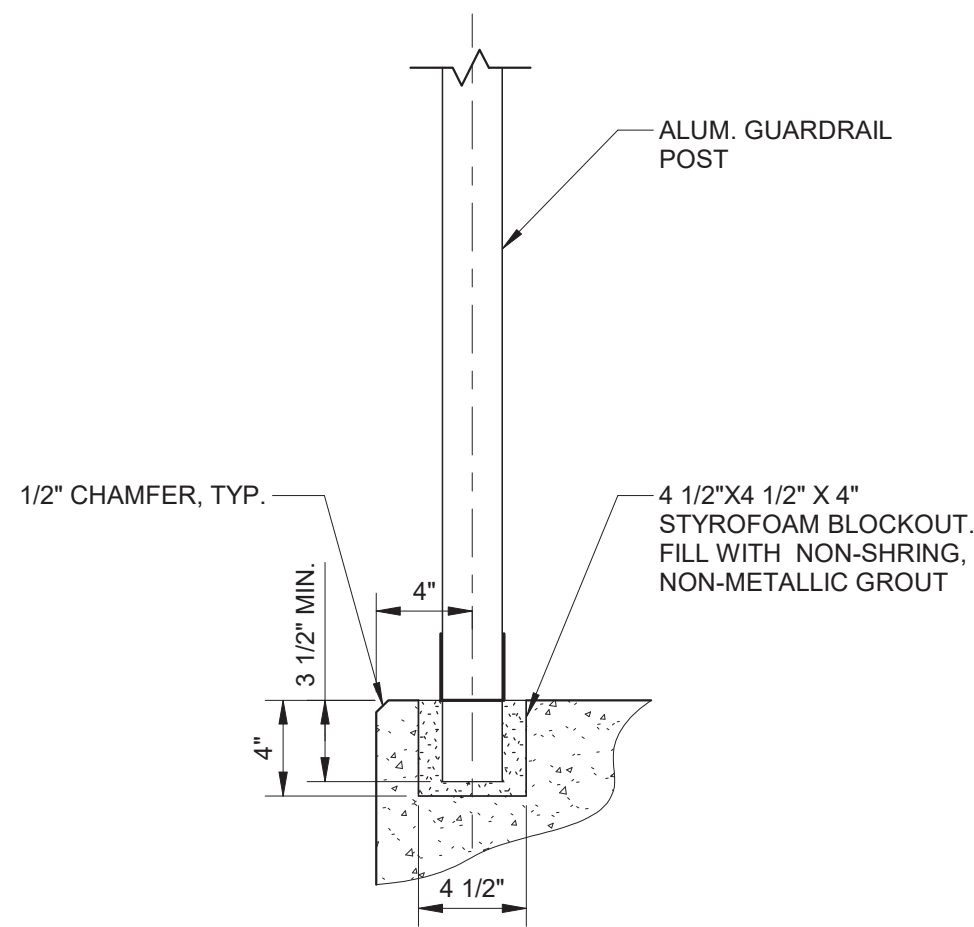

2 GUARDRAIL POST INSTALLATION IN CONCRETE
1 1/2" = 1'-0"

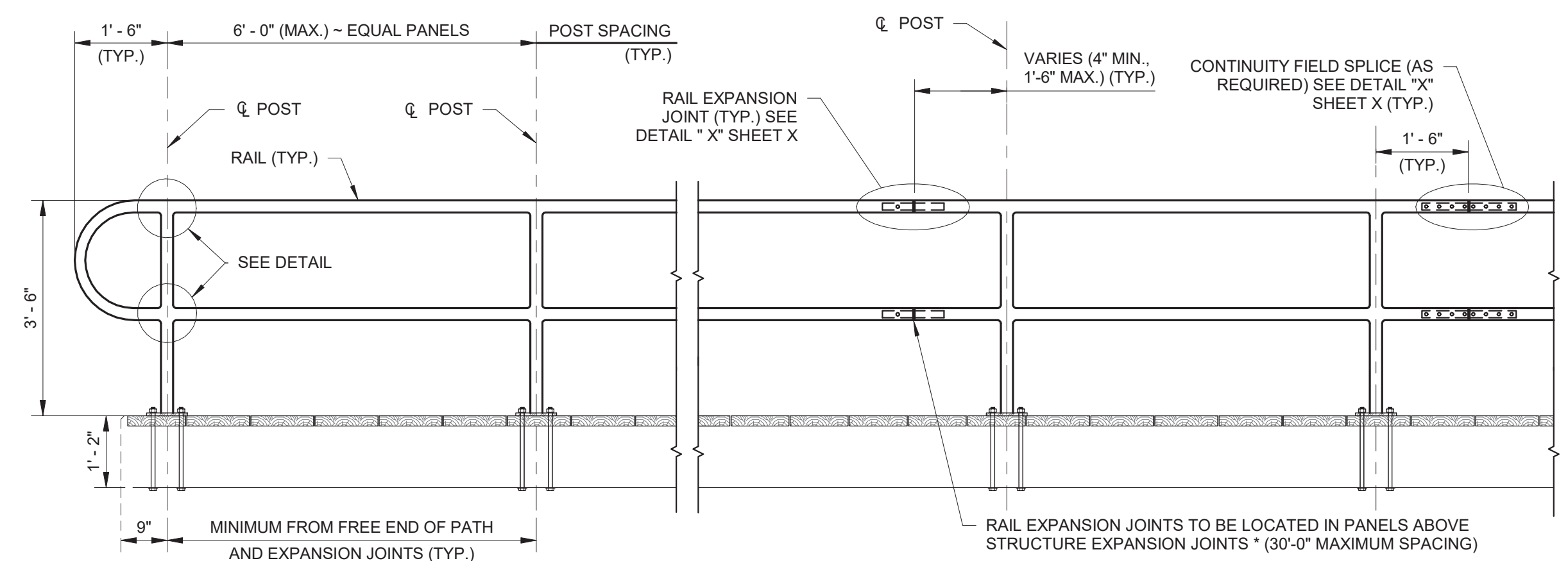

3 ALUMINUM GUARDRAIL TYP. ELEVATION
1/2" = 1'-0"

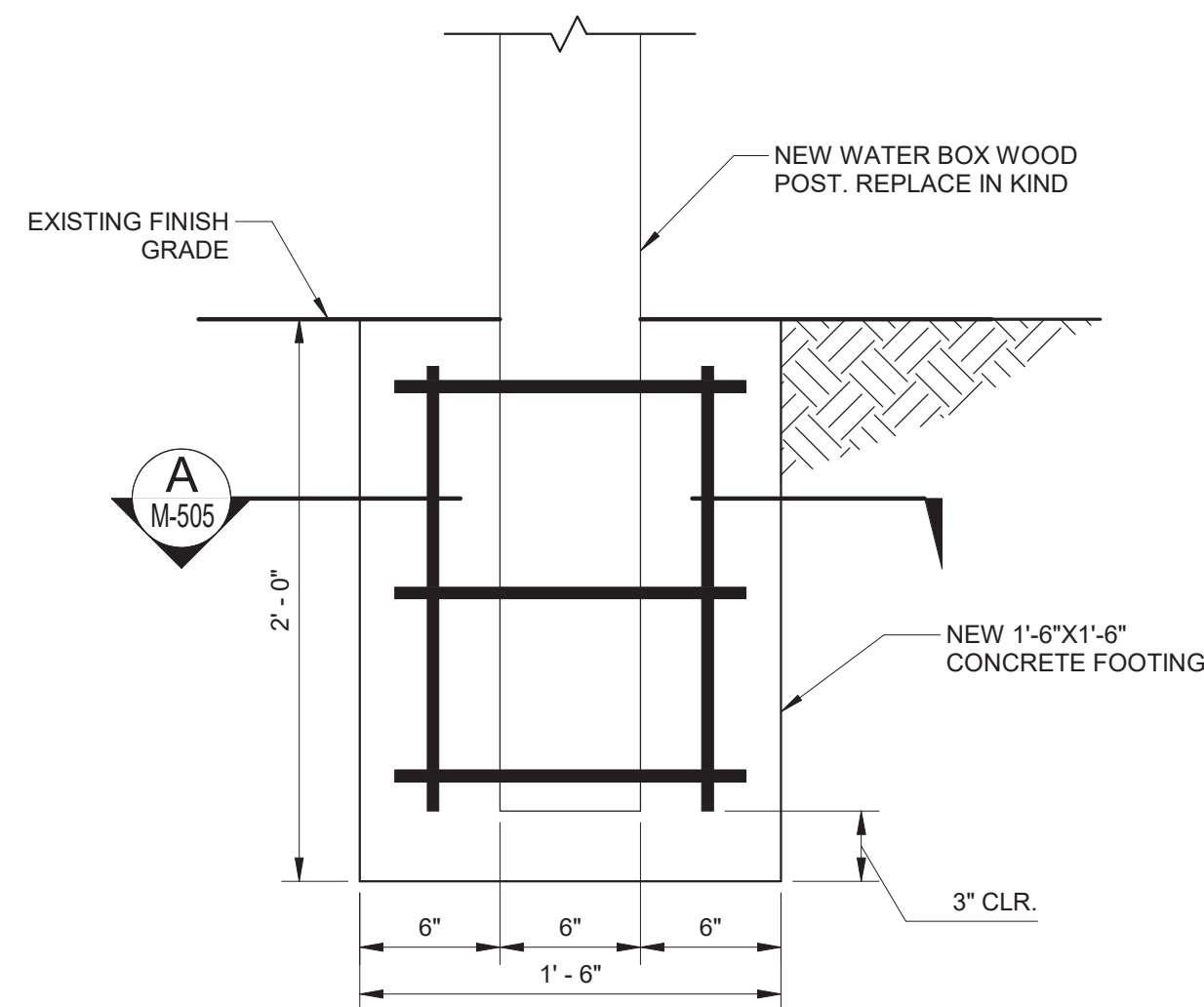

4 WATER BOX FOOTING - DETAIL
1 1/2" = 1'-0"

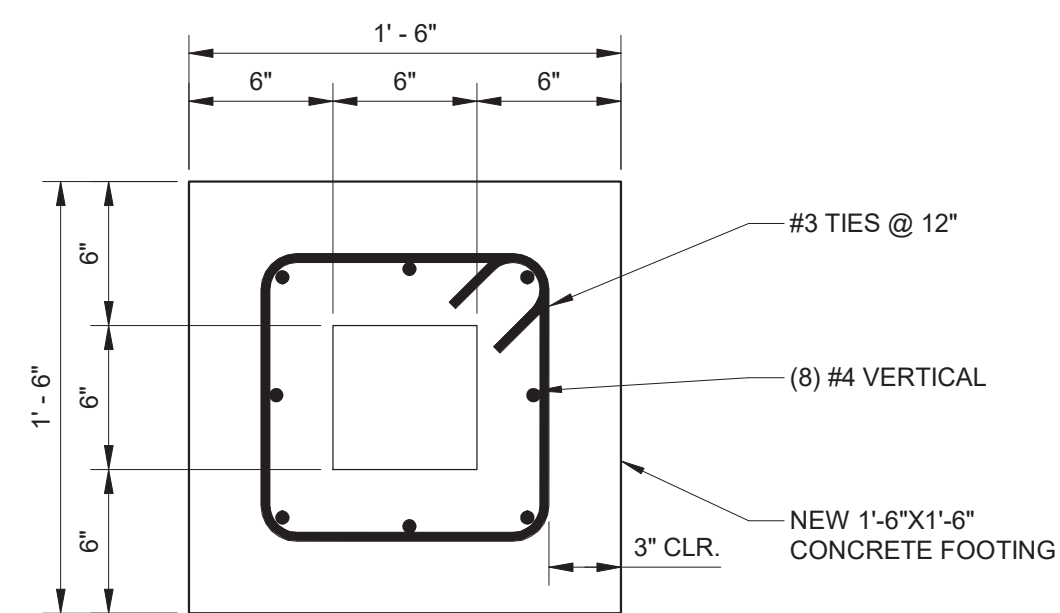

SECTION A
1 1/2" = 1'-0"

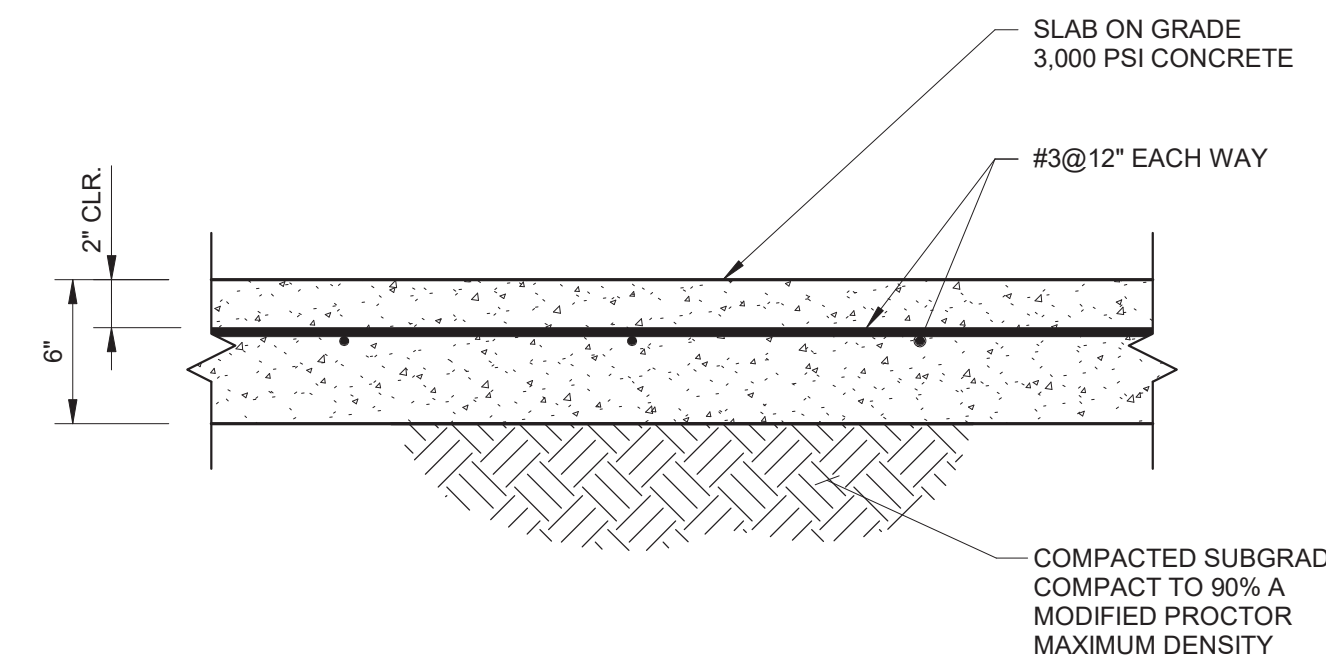

5 SLAB ON GRADE TYPICAL - DETAIL
1 1/2" = 1'-0"

NOTES:

- CONTRACTOR TO COORDINATE FINAL LOCATION OF 4\"/>

ANSI D (9/19/22)

M M
MOTT MACDONALD
930 Main Campus Drive,
Suite 200
Raleigh, NC 27606
License No. F-0669
T +1 (919) 552 2253
F +1 (919) 552 2254
www.mottmacamericas.com

GRAPHIC SCALE

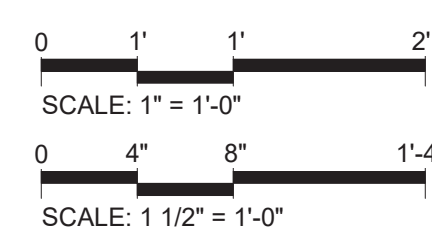

Digitally signed by Kristopher P Pagan-Cruz
Date: 2026.05.01 16:36:07-04'00'

PROJECT ENGINEER
NORTH CAROLINA
PROFESSIONAL
SEAL
044825
KRISTOPHER P Pagan-Cruz

Designed By	JAVIER QUIROS	County	DARE COUNTY
Entered By	VICTOR PADILLA	Division	FERRY DIVISION
Project Engineer	KRISTOPHER PAGAN	Plan Date	1-14-26
Project Manager	ALLISON THORBURN		
Rev.	Date	Drawn	Description
			Ch'kd
			App'd

NCDOT HATTERAS FERRY DOCK REPLACEMENT

M-505 MISCELLANEOUS DETAILS
(5 OF 5)

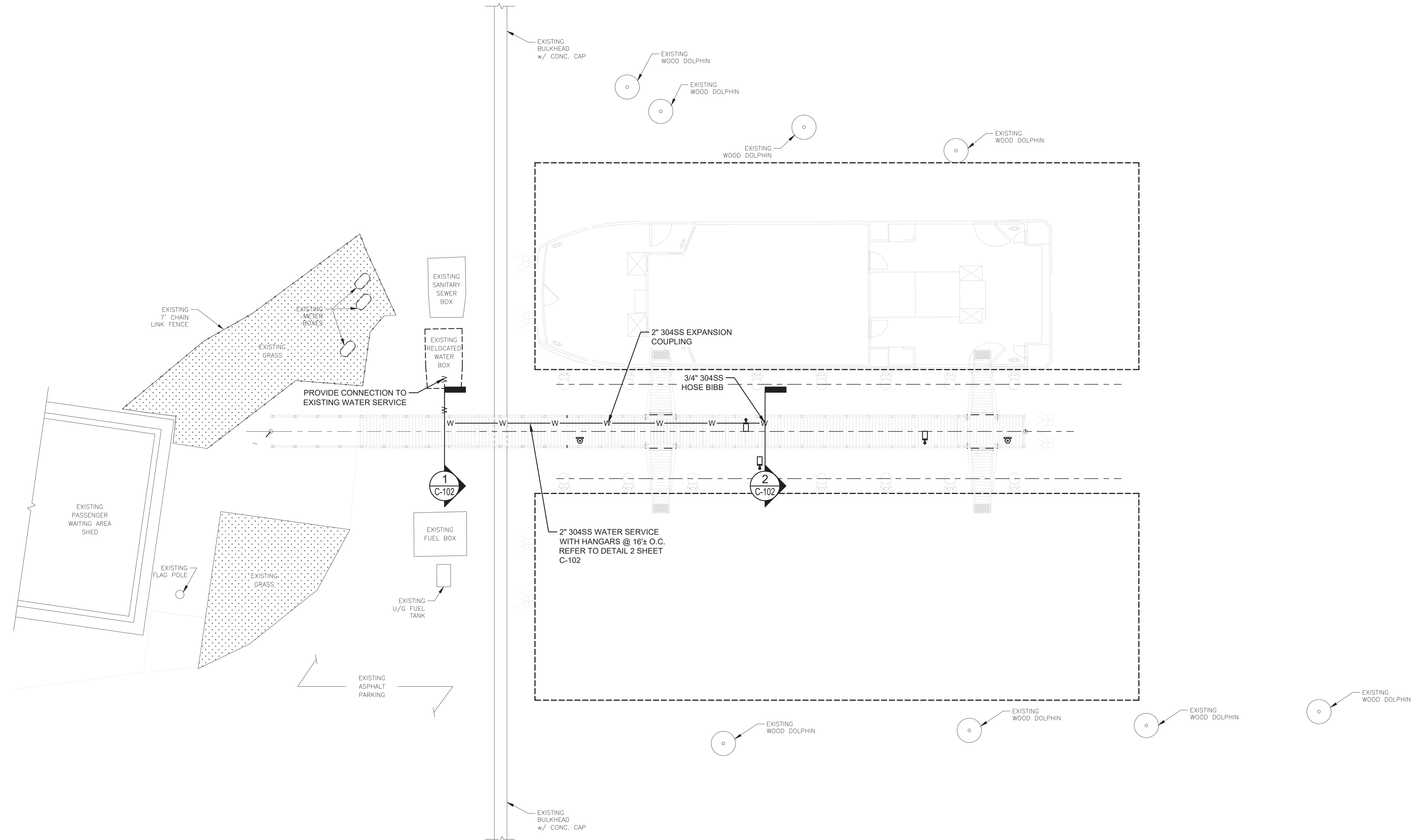

NOTES:

1. THE EXISTING WATER BOX SHALL BE RELOCATED BY CONTRACTOR. LOCATION SHOWN IN PLAN IS INDICATIVE AND FOR REFERENCE ONLY. FINAL LOCATION TO BE COORDINATED BY THE CONTRACTOR WITH NCDOT. SEE SHEETS D-101 AND M-101 FOR ADDITIONAL INFORMATION.
2. BELOW GRADE PIPING SHALL BE SOLVENT WELD 2" SCH. 80 PVC MEETING NSF/ANSI STANDARD 61.
3. ABOVE GRADE WATER PIPING AND FITTINGS SHALL BE SCH. 80 304 STAINLESS STEEL MEETING NSF/ANSI STANDARD 61.
4. PLANS DO NOT PURPORT THAT ALL REQUIRED FITTINGS OR PIPING CONFIGURATIONS ARE SHOWN. CONTRACTOR SHALL INVESTIGATE EXISTING WATER SYSTEM AND PROVIDE ALL PIPING AND/OR FITTINGS NECESSARY TO MAKE LINE AND GRADE ADJUSTMENTS TO CONNECT TO THE EXISTING WATER SYSTEM AND TO PROVIDE A COMPLETE AND FUNCTIONAL WATER SERVICE/HOSE BIBB.

1 WATER SERVICE - PLAN
1" = 10'

Digitally signed by Kristopher P Pagan-Cruz
Date: 2026.02.17 11:30:36-05'00'

M M
MOTT MACDONALD
930 Main Campus Drive,
Suite 200
Raleigh, NC 27606
License No. F-0669
T +1 (919) 552 2253
F +1 (919) 552 2254
www.mottmacamericas.com

GRAPHIC SCALE
0 5' 10' 20'
SCALE: 1" = 10'

PROJECT ENGINEER
NORTH CAROLINA PROFESSIONAL SEAL
KRISTOPHER PHERNANDO PAGONCruz
044825

Designed By	STEVEN WHITE	County	DARE COUNTY
Entered By	GORDON EDWARDS	Division	FERRY DIVISION
Project Engineer	KRISTOPHER PAGAN	Plan Date	1-14-26
Project Manager	ALLISON THORBURN		
Rev.	Date	Drawn	Description

NCDOT HATTERAS FERRY DOCK REPLACEMENT

C-101 WATER SERVICE PLAN

SHEET 18 OF 26

ANSI D (34"x22")

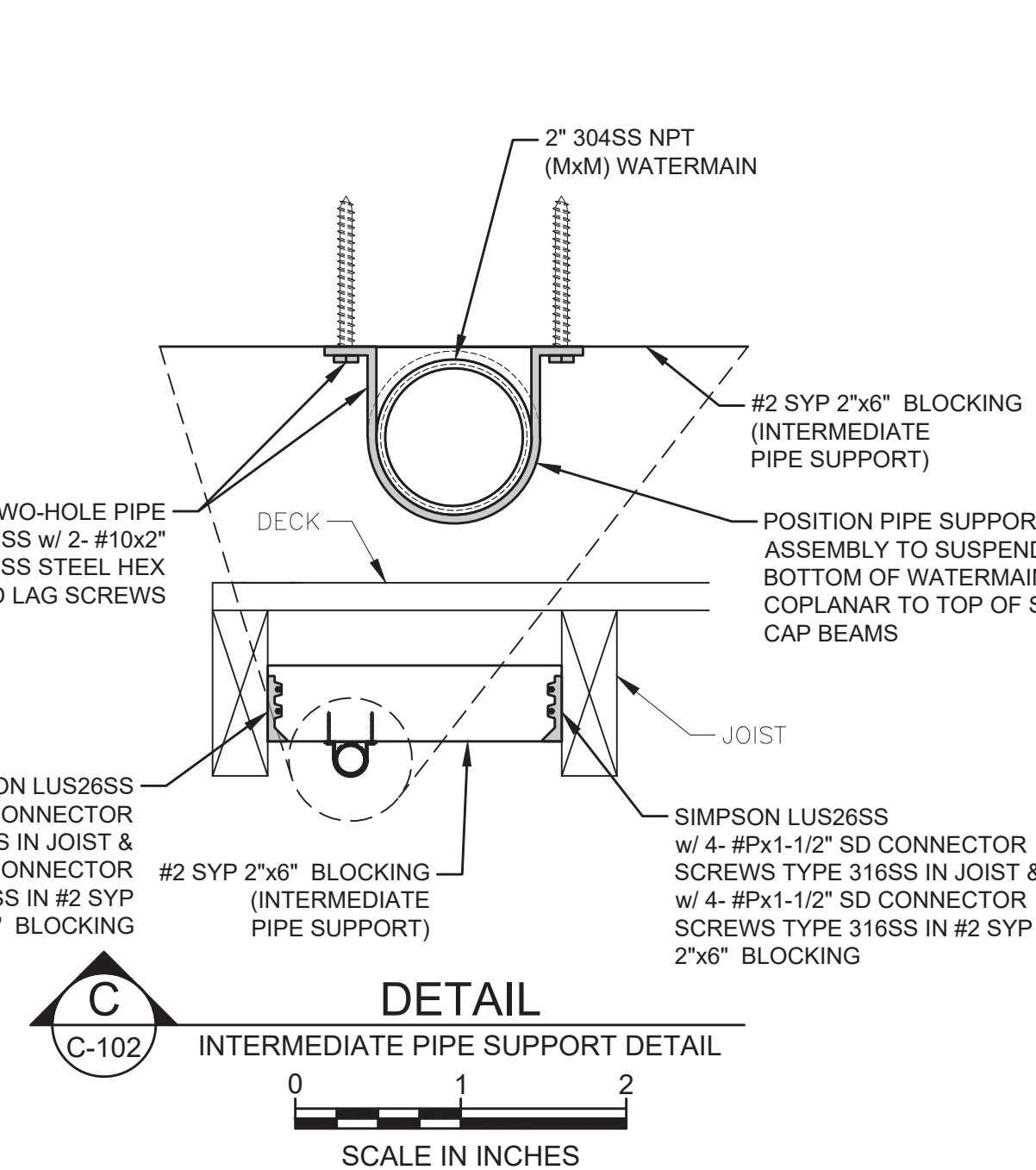
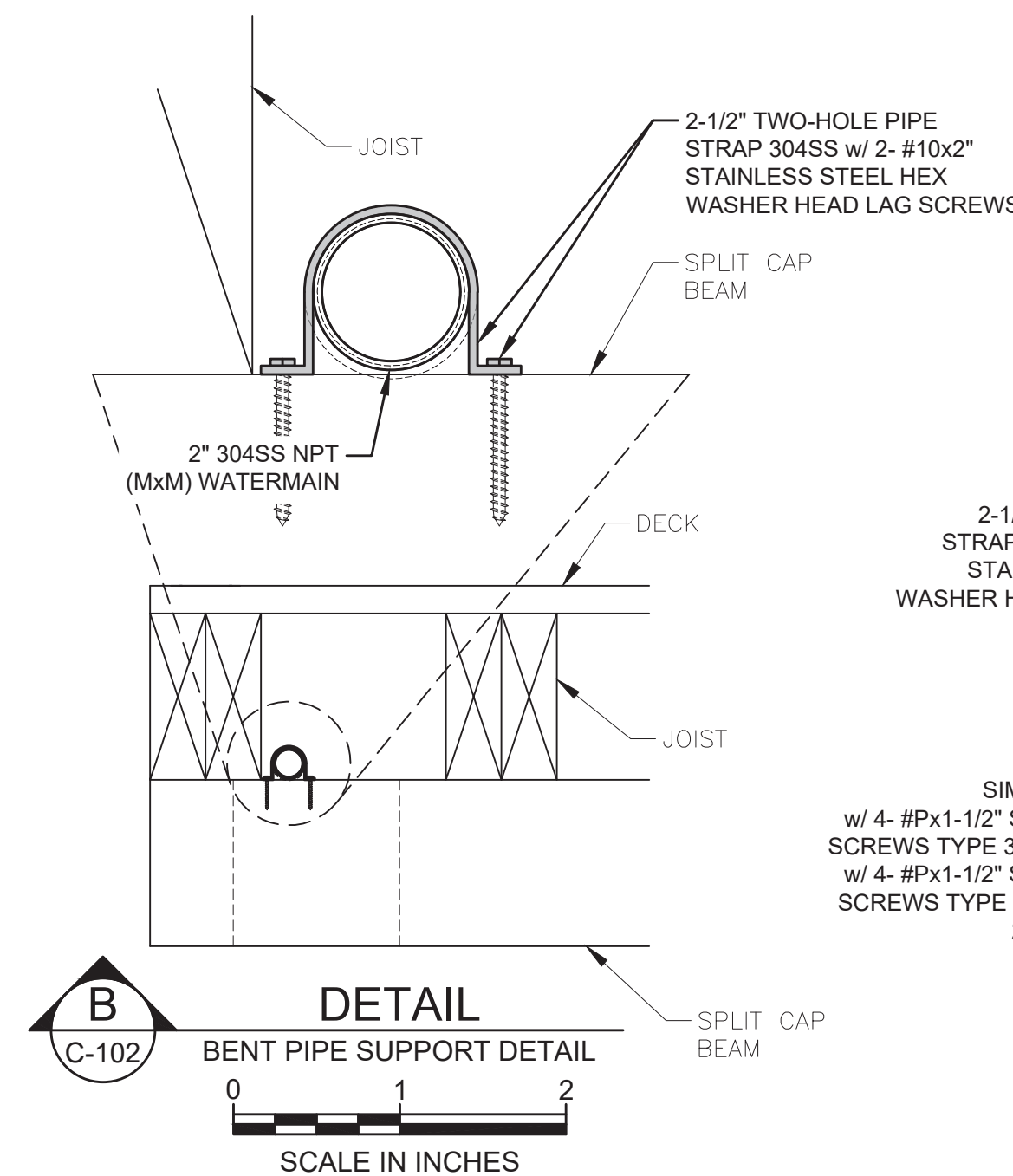
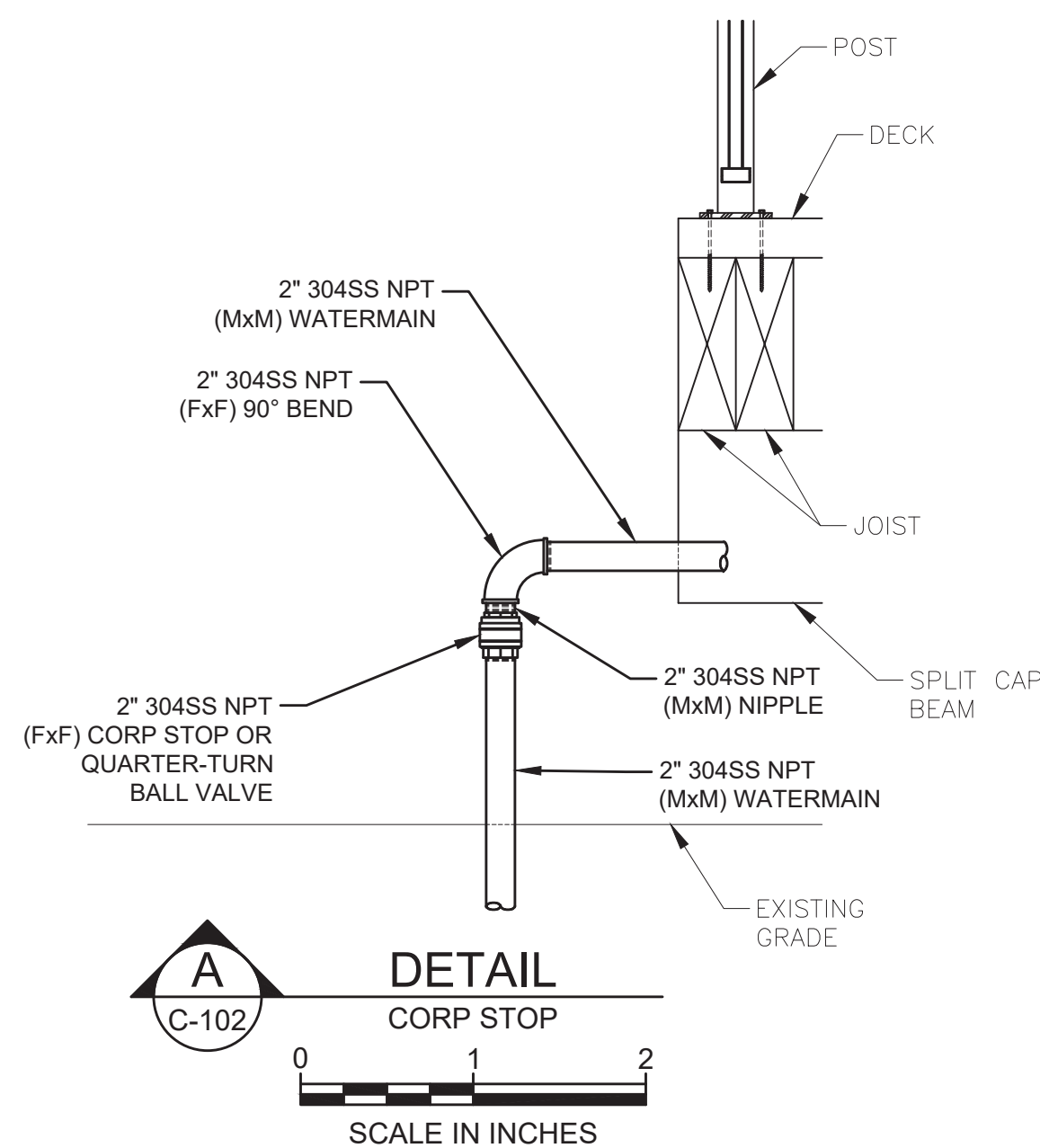
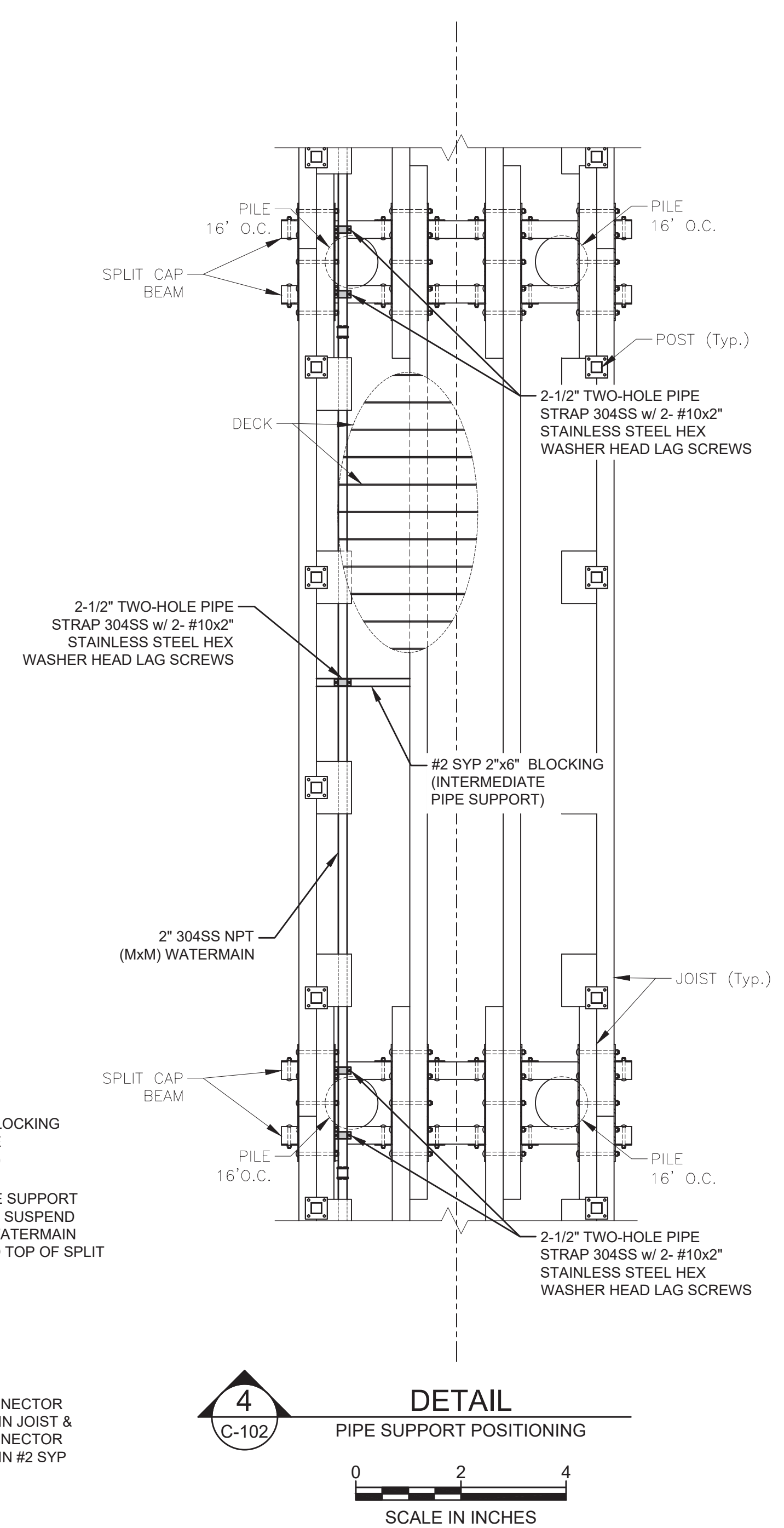
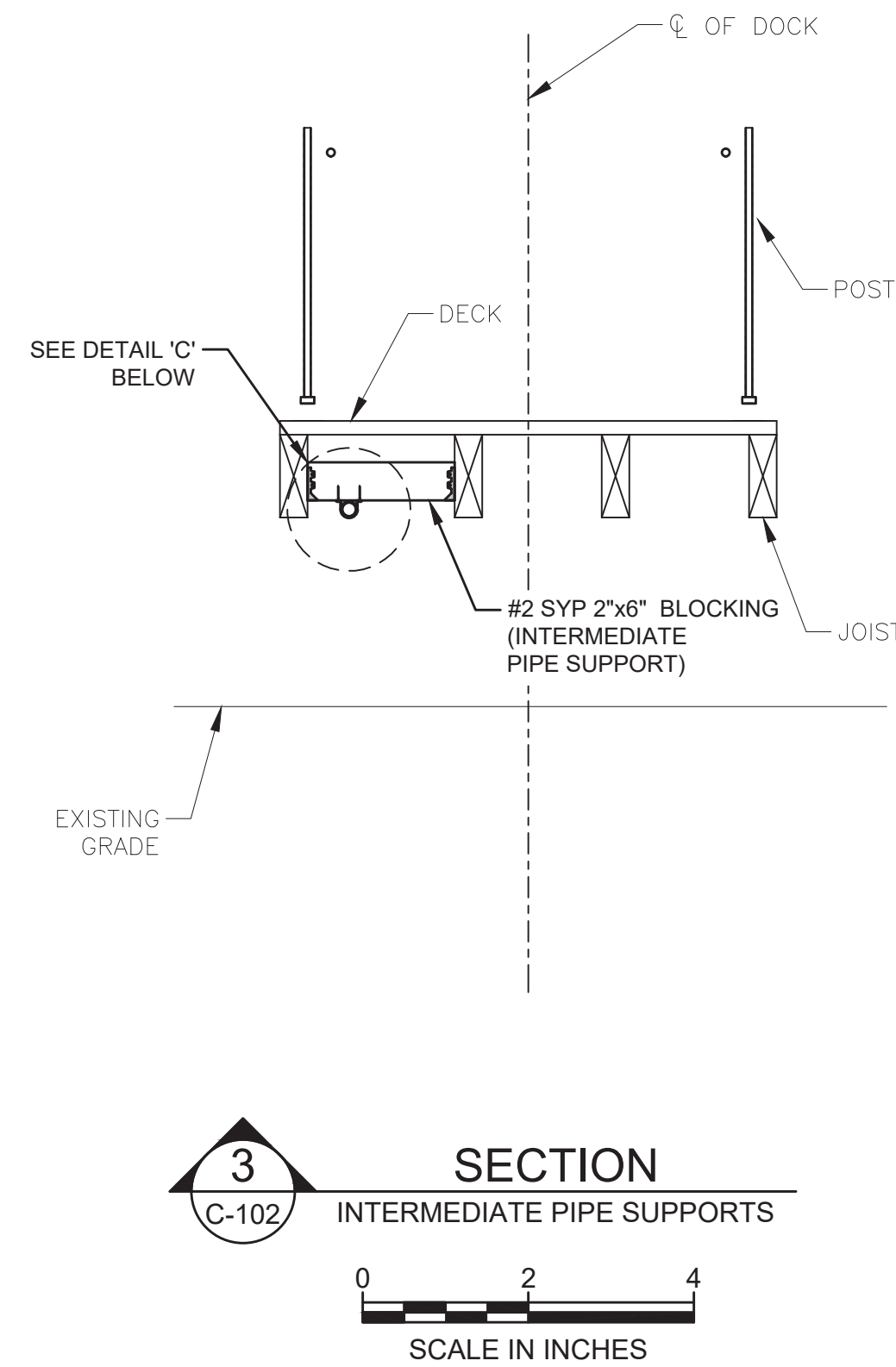
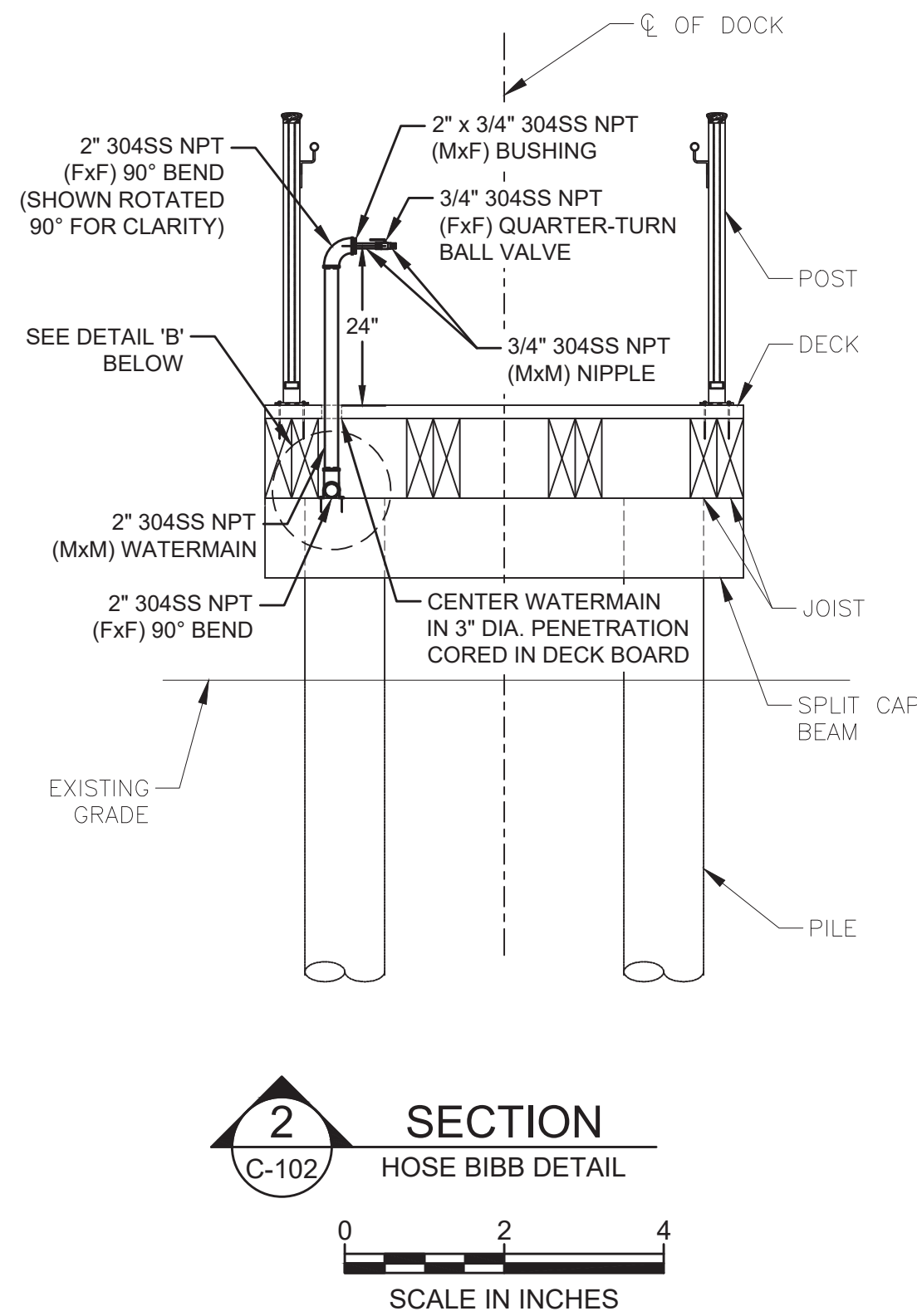
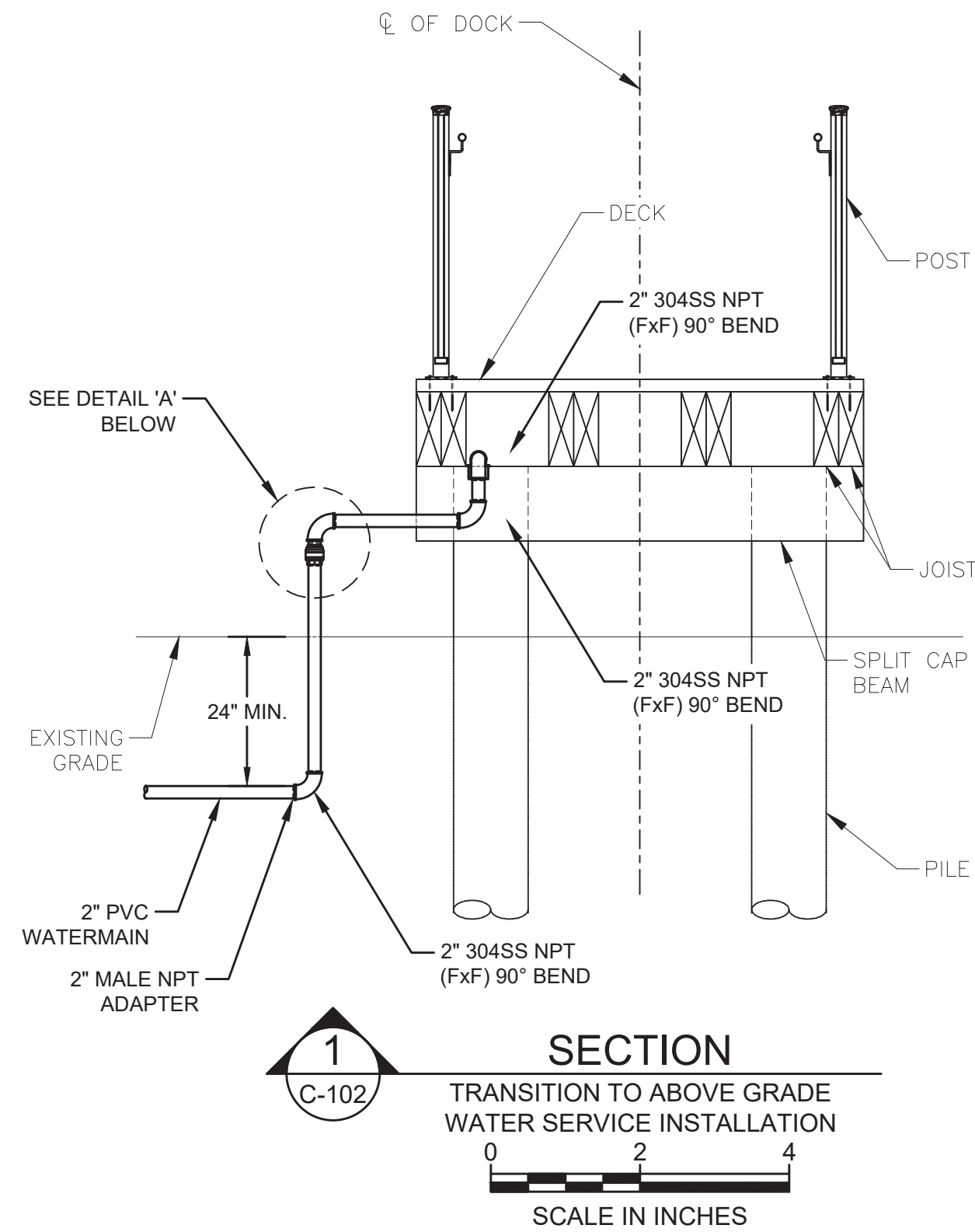

NOTES:

1. THE EXISTING WATER BOX SHALL BE RELOCATED BY CONTRACTOR. LOCATION SHOWN IN PLAN IS INDICATIVE AND FOR REFERENCE ONLY. FINAL LOCATION TO BE COORDINATED BY THE CONTRACTOR WITH NCDOT. SEE SHEETS D-101 AND M-101 FOR ADDITIONAL INFORMATION.
2. BELOW GRADE PIPING SHALL BE SOLVENT WELD 2" SCH. 80 PVC MEETING NSF/ANSI STANDARD 61.
3. ABOVE GRADE WATER PIPING AND FITTINGS SHALL BE SCH. 80 304 STAINLESS STEEL MEETING NSF/ANSI STANDARD 61.
4. PLANS DO NOT PURPORT THAT ALL REQUIRED FITTINGS OR PIPING CONFIGURATIONS ARE SHOWN. CONTRACTOR SHALL INVESTIGATE EXISTING WATER SYSTEM AND PROVIDE ALL PIPING AND/OR FITTINGS NECESSARY TO MAKE LINE AND GRADE ADJUSTMENTS TO CONNECT TO THE EXISTING WATER SYSTEM AND TO PROVIDE A COMPLETE AND FUNCTIONAL WATER SERVICE/HOSE BIBB.

1 WATER SERVICE DETAILS
1" = 2'

Digitally signed by Kristopher P Pagan-Cruz
Date: 2026.02.17 11:31:03-05'00'

M M
MOTT MACDONALD
930 Main Campus Drive,
Suite 200
Raleigh, NC 27606
License No. F-0669
T +1 (919) 552 2254
F +1 (919) 552 2254
www.mottmacamericas.com

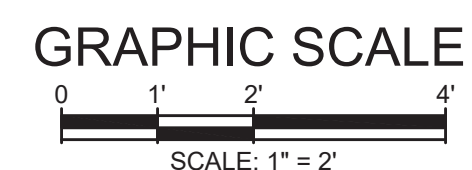

PROJECT ENGINEER
NORTH CAROLINA PROFESSIONAL SEAL
044825
KRISTOPHER PHERNANDO PAPANCRUZ

Designed By	STEVEN WHITE	County	DARE COUNTY
Entered By	GORDON EDWARDS	Division	FERRY DIVISION
Project Engineer	KRISTOPHER PAGAN	Plan Date	1-14-26
Project Manager	ALLISON THORBURN		
Rev.	Date	Drawn	Description
			Ch'k'd
			App'd

NCDOT HATTERAS FERRY DOCK REPLACEMENT

C-102 WATER SERVICE DETAILS

GENERAL NOTES FOR SOIL EROSION AND SEDIMENT CONTROL:

- ALL EROSION AND SEDIMENT CONTROL PRACTICES TO BE INSTALLED PRIOR TO ANY MAJOR SOIL DISTURBANCE, OR IN THEIR PROPER SEQUENCE, AND MAINTAINED UNTIL PERMANENT PROTECTION IS ESTABLISHED.
- ANY DISTURBED AREAS THAT WILL BE LEFT EXPOSED MORE THAN 30 DAYS, AND NOT SUBJECT TO CONSTRUCTION TRAFFIC, WILL IMMEDIATELY RECEIVE A TEMPORARY SEEDING. IF THE SEASON PREVENTS THE ESTABLISHMENT OF A TEMPORARY COVER, THE DISTURBED AREAS WILL BE MULCHED WITH STRAW, OR EQUIVALENT MATERIAL, AT A RATE OF TWO (2) TONS PER ACRE, ACCORDING TO STATE STANDARDS.
- ANY STEEP SLOPES RECEIVING PIPELINE INSTALLATION WILL BE BACKFILLED AND STABILIZED DAILY, AS THE INSTALLATION PROCEEDS (I.E. SLOPES GREATER THAN 3:1).
- A CRUSHED LIMEROCK, VEHICLE WHEEL-CLEANING BLANKET SHALL BE INSTALLED AT THE CONTRACTOR'S STAGING YARD AND/OR STOCKPILE AREAS TO PREVENT OFF-SITE TRACKING OF SEDIMENT BY CONSTRUCTION VEHICLES ONTO PUBLIC ROADS. BLANKET SHALL BE 15FT. X 50FT. X 6IN. (MINIMUM), CRUSHED LIMEROCK 2 1/2 INCHES IN DIAMETER. SAID BLANKET SHALL BE UNDERLAIN WITH A FDOT CLASS 3 SYNTHETIC FILTER FABRIC AND MAINTAINED IN GOOD ORDER.
- CONDUIT OUTLET PROTECTION MUST BE INSTALLED AT ALL REQUIRED OUTFALLS PRIOR TO THE DRAINAGE SYSTEM BECOMING OPERATIONAL.
- UNFILTERED DEWATERING IS NOT PERMITTED. THE CONTRACTOR SHALL TAKE ALL NECESSARY PRECAUTIONS DURING ALL DEWATERING OPERATIONS TO MINIMIZE SEDIMENT TRANSFER.
- SHOULD THE CONTROL OF DUST AT THE SITE BE NECESSARY, THE SITE WILL BE SPRINKLED UNTIL THE SURFACE IS WET.
- ALL SOIL WASHED, DROPPED, SPILLED OR TRACKED OUTSIDE THE LIMIT OF DISTURBANCE OR ONTO PUBLIC RIGHTS-OF-WAY WILL BE REMOVED IMMEDIATELY.
- THE PROPERTY OWNER SHALL BE RESPONSIBLE FOR ANY EROSION OR SEDIMENTATION THAT MAY OCCUR BELOW STORMWATER OUTFALLS OR OFFSITE AS A RESULT OF CONSTRUCTION OF THE PROJECT.
- ALL SOIL STOCKPILES ARE TO BE TEMPORARILY STABILIZED IN ACCORDANCE WITH SOIL EROSION AND SEDIMENT CONTROL NOTE NUMBER 2 (ABOVE).
- THE SITE SHALL AT ALL TIMES BE GRADED AND MAINTAINED SUCH THAT ALL STORM WATER RUNOFF IS DIVERTED TO SOIL EROSION AND SEDIMENT CONTROL FACILITIES.
- ALL SEDIMENTATION STRUCTURES SHALL BE INSPECTED AND MAINTAINED REGULARLY.
- ALL CATCH BASIN INLETS SHALL BE PROTECTED WITH HAY BALES AS SHOWN ON DETAIL.
- ANY AREAS USED FOR THE CONTRACTOR'S STAGING, INCLUDING BUT NOT LIMITED TO, TEMPORARY STORAGE OF STOCKPILED MATERIALS (E.G. CRUSHED STONE, QUARRY PROCESS STONE, SELECT FILL, EXCAVATED MATERIALS, ETC.), SHALL BE ENTIRELY PROTECTED BY A SILT FENCE ALONG THE LOW ELEVATION SIDE TO CONTROL SEDIMENT RUNOFF.

* WHERE APPLICABLE

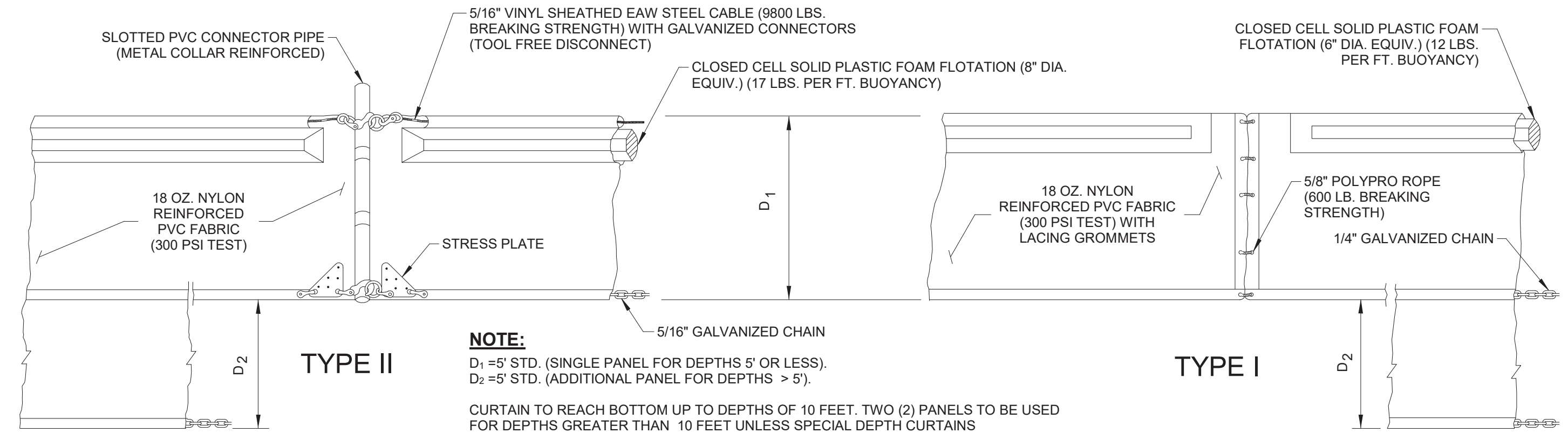

NOTE:
D₁ = 5' STD. (SINGLE PANEL FOR DEPTHS 5' OR LESS).
D₂ = 5' STD. (ADDITIONAL PANEL FOR DEPTHS > 5').
CURTAIN TO REACH BOTTOM UP TO DEPTHS OF 10 FEET. TWO (2) PANELS TO BE USED FOR DEPTHS GREATER THAN 10 FEET UNLESS SPECIAL DEPTH CURTAINS SPECIFICALLY CALLED FOR IN THE PLANS OR AS DETERMINED BY THE ENGINEER.

NOTICE:
COMPONENTS OF TYPES I AND II MAY BE SIMILAR OR IDENTICAL TO PROPRIETARY DESIGNS. ANY INFRINGEMENT ON THE PROPRIETARY RIGHTS OF THE DESIGNER SHALL BE THE SOLE RESPONSIBILITY OF THE USER. SUBSTITUTIONS FOR TYPES I AND II SHALL BE AS APPROVED BY THE ENGINEER.

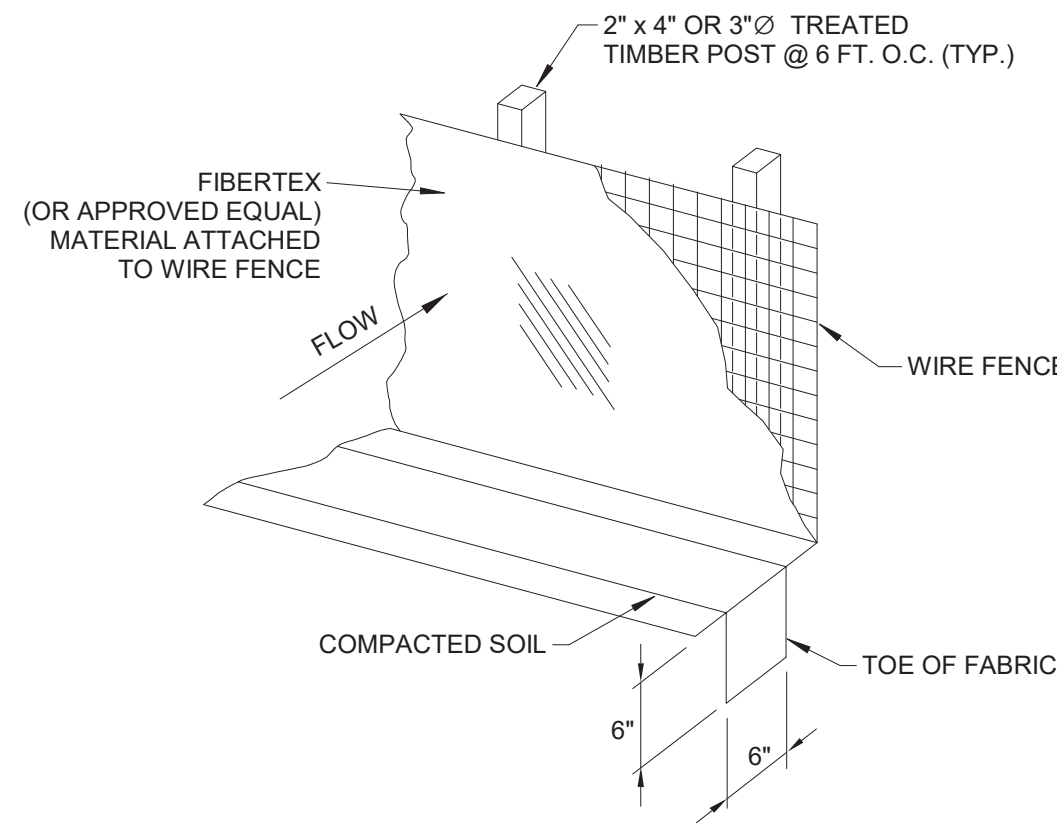

2 SILT FENCE DETAIL
N.T.S.

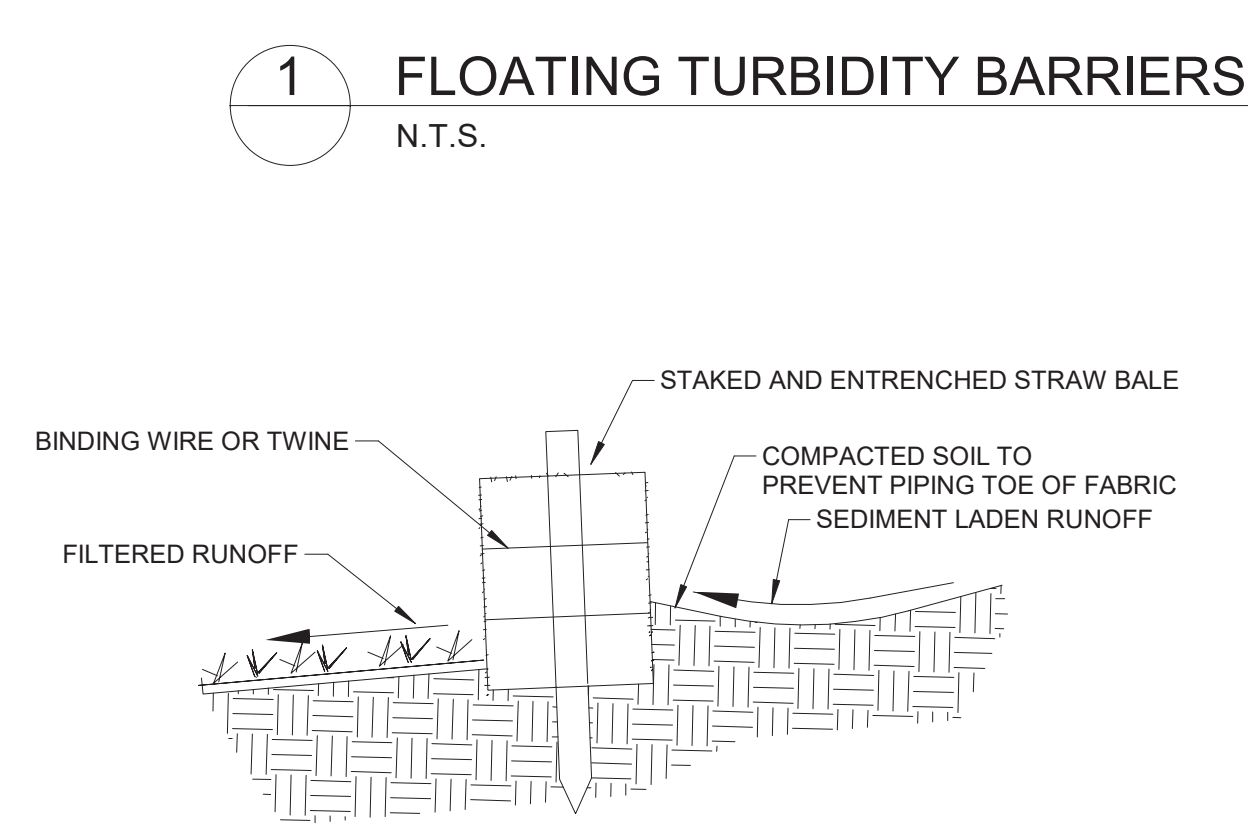

3 DETAIL OF PROPERLY INSTALLED STRAW BALE
N.T.S.

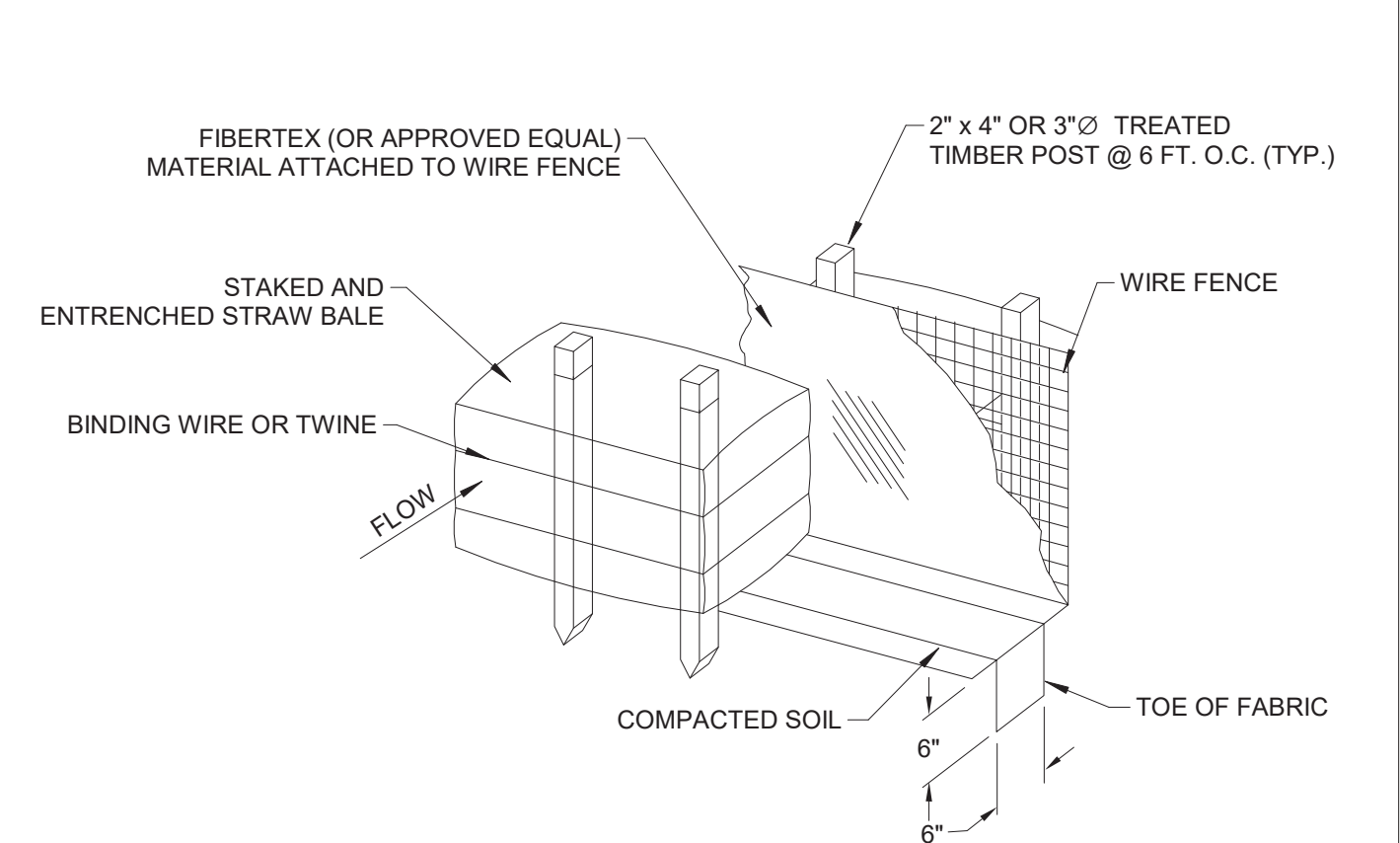

4 SILT FENCE W/ HAYBALES DETAIL
N.T.S.

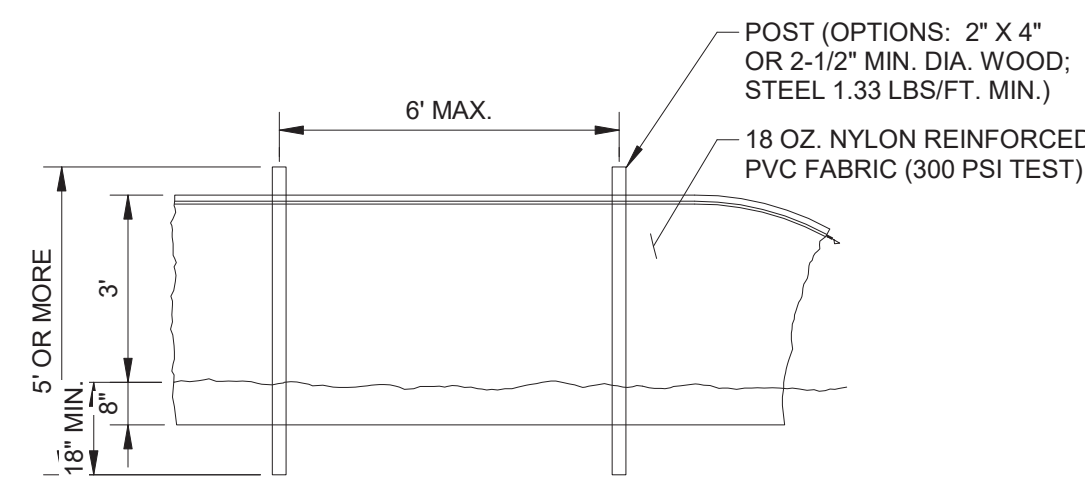

5 STAKED TURBIDITY BARRIER
N.T.S.

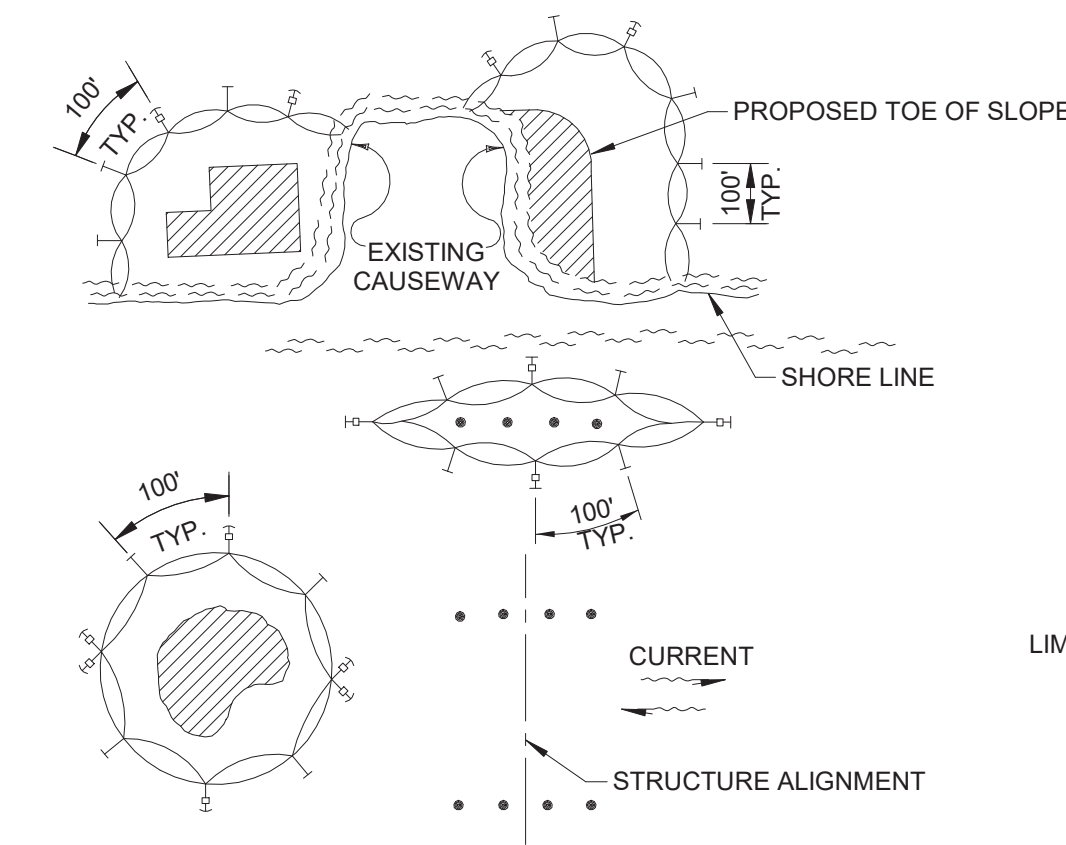

- TURBIDITY BARRIERS ARE TO BE USED IN ALL PERMANENT BODIES OF WATER REGARDLESS OF WATER DEPTH.
- NUMBER AND SPACING OF ANCHORS DEPENDENT ON CURRENT VELOCITIES.
- DEPLOYMENT OF BARRIER AROUND PILE LOCATIONS MAY VARY TO ACCOMMODATE CONSTRUCTION OPERATIONS.
- NAVIGATION MAY REQUIRE SEGMENTING BARRIER DURING CONSTRUCTION OPERATIONS.
- FOR ADDITIONAL INFORMATION SEE SECTION 104 OF THE STANDARD SPECIFICATIONS.

LEGEND:

- PILE LOCATIONS
- ▨ DREDGE OR FILL AREA
- MOORING BUOY W/ANCHOR
- ANCHOR
- ↔ BARRIER MOVEMENT DUE TO CURRENT ACTION

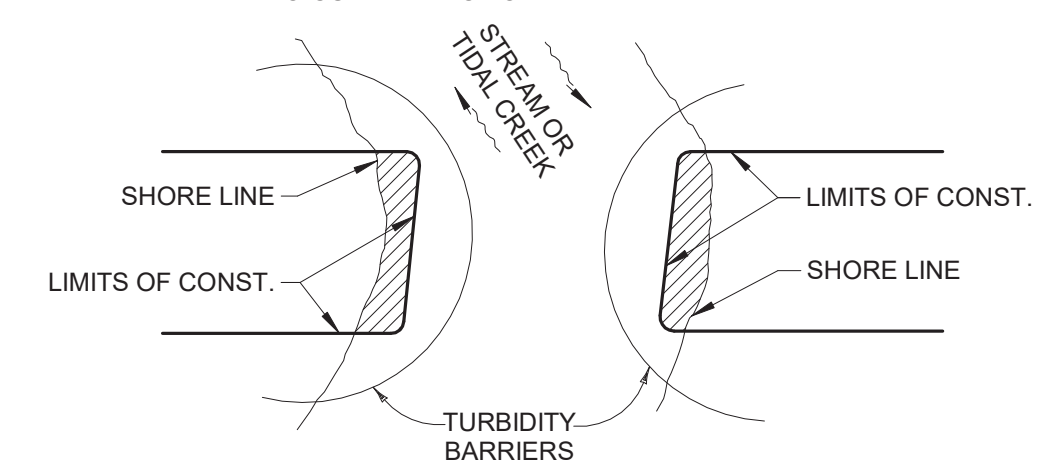

NOTE:

TURBIDITY BARRIERS FOR FLOWING STREAMS AND TIDAL CREEKS MAY BE EITHER FLOATING, OR STAKED TYPES OR ANY COMBINATIONS OF TYPES THAT WILL SUIT SITE CONDITIONS AND MEET EROSION CONTROL AND WATER QUALITY REQUIREMENTS. THE BARRIER TYPE(S) WILL BE AT THE CONTRACTOR'S OPTION UNLESS OTHERWISE SPECIFIED IN THE PLANS. HOWEVER PAYMENT WILL BE UNDER THE PAY ITEM(S) ESTABLISHED IN THE PLANS FOR FLOATING TURBIDITY BARRIER AND/OR STAKED TURBIDITY BARRIER. POSTS IN STAKED TURBIDITY BARRIERS TO BE INSTALLED IN VERTICAL POSITION UNLESS OTHERWISE DIRECTED BY THE ENGINEER.

6 TURBIDITY BARRIER APPLICATIONS
N.T.S.

Digitally signed by Kristopher P Pagan-Cruz
Date: 2026.02.17 11:31:12-05'00'

MOTT MACDONALD
930 Main Campus Drive,
Suite 200
Raleigh, NC 27606
License No. F-0669
T +1 (919) 552 2253
F +1 (919) 552 2254
www.mottmacamericas.com

GRAPHIC SCALE

PROJECT ENGINEER
NORTH CAROLINA PROFESSIONAL ENGINEER SEAL
KRISTOPHER P. PAGAN-CRUZ
044825

Designed By	STEVEN WHITE	County	DARE COUNTY
Entered By	VICTOR PADILLA	Division	FERRY DIVISION
Project Engineer	KRISTOPHER PAGAN	Plan Date	1-14-26
Project Manager	ALLISON THORBURN		
Rev.	Date	Drawn	Description
			Ch'k'd
			App'd

NCDOT HATTERAS FERRY DOCK REPLACEMENT

C-103 EROSION CONTROL DETAILS

ANSI D (9/15/22)

GENERAL NOTES

- ALL WORK SHALL CONFORM TO THE REQUIREMENTS OF THE NATIONAL ELECTRICAL CODE, NATIONAL ELECTRIC SAFETY CODE, N.F.P.A., O.S.H.A. REGULATIONS AND ALL OTHER EXISTING CODES AND REGULATIONS OF AUTHORITIES WHICH HAVE JURISDICTION.
- THE CONTRACT DRAWINGS ARE DIAGRAMMATIC IN NATURE AND NOT EVERY DETAIL OR CONDUIT IS SHOWN. EXISTING CONDITIONS AND DIMENSIONS SHALL BE VERIFIED IN THE FIELD BEFORE COMMENCING ANY FABRICATION, ORDERING ANY MATERIAL, OR PERFORMING ANY WORK. ANY DEPARTURE FROM CONCEPT SHOWN ON THE CONTRACT DRAWINGS SHALL BE SUBMITTED TO THE ENGINEER FOR APPROVAL. ALL ELECTRICAL EQUIPMENT SHOWN ON THE DRAWINGS AND/OR REQUIRED FOR THE FULL INTEGRITY OF THE CONTRACT SHALL BE FURNISHED, INSTALLED AND CONNECTED BY THE CONTRACTOR, EXCEPT WHERE EQUIPMENT SHOWN IS IDENTIFIED AS "EXISTING" OR OTHERWISE NOTED ON THE DRAWINGS.
- UNLESS OTHERWISE NOTED, EQUIPMENT AND MATERIALS TO BE PROVIDED SHALL BEAR LISTING AND LABELING BY A NATIONALLY RECOGNIZED TESTING AGENCY WHERE SUCH STANDARD HAD BEEN ESTABLISHED FOR THAT TYPE OF EQUIPMENT/MATERIAL.
- THE CONTRACTOR SHALL SUBMIT DETAILED EQUIPMENT LAYOUT PLANS, SECTIONS, AND MOUNTING DETAILS SHOWING PROPOSED LOCATION OF ALL EQUIPMENT AND REQUIRED WORKING/SERVICE CLEARANCES PRIOR TO INSTALLATION.
- CONTRACTOR SHALL VISIT THE PROJECT SITE AND EXAMINE AND CONFIRM EXISTING CONDITIONS. ALL CHANGES SHALL BE PRESENTED DURING SHOP DRAWING SUBMITTALS FOR ENGINEER'S APPROVAL.
- CONDUITS SHALL CONTAIN AN INSULATED GROUND WIRE BONDED TO ENCLOSURES AND SIZED IN ACCORDANCE WITH THE REQUIREMENTS OF THE NEC, IF SIZE IS NOT SHOWN ON THE CONTRACT DRAWINGS.
- THE CONTRACTOR SHALL PROVIDE CONDUIT FITTINGS, CONNECTORS, CLAMPS, HARDWARE, HANGERS, AND SUPPORTS AS NECESSARY FOR A COMPLETE INSTALLATION.
- THE CONTRACTOR SHALL PROVIDE TAGS FOR EQUIPMENT, CONDUITS, AND CABLES THAT ARE INSTALLED UNDER THIS CONTRACT. TAG IDENTIFICATIONS SHALL BE IN ACCORDANCE WITH CONTRACT DRAWINGS. TAGS FOR CONDUITS SHALL BE AS DESCRIBED IN SPECIFICATIONS.
- UNUSED OPENINGS IN CONDUITS, BOXES, DISCONNECT SWITCHES, CABINETS, AND PANEL BOARDS SHALL BE CAPPED OR PLUGGED.
- UPDATE EXISTING PANELBOARD DIRECTORIES TO REFLECT THE CIRCUITING IN EXISTING PANELBOARDS AFFECTED BY THIS ALTERATION.
- CONTRACTOR SHALL PROVIDE THE NECESSARY MATERIALS, LABOR AND ATTENDANCE FOR THE OPERATION OF TEMPORARY LIGHT AND CONSTRUCTION POWER AS REQUIRED DURING WORKING HOURS FOR THE ENTIRE CONSTRUCTION PERIOD.
- CONTRACTOR SHALL MAINTAIN CONTINUITY OF ANY EXISTING CIRCUITS AFFECTED BY THIS ALTERATION. RECONNECT ALL ALTERED OR REROUTED WORK TO ITS FULLY FUNCTIONAL STATE PRIOR TO ALTERATION.
- PROVIDE ALL NECESSARY TEMPORARY WIRING TO MAINTAIN EXISTING INSTALLATIONS WHICH MUST REMAIN IN SERVICE DURING CONSTRUCTION PERIOD.
- ALL BRANCH CIRCUITS OVER 75 FEET IN LENGTH SHALL BE RUN WITH #10 CONDUCTOR, UNLESS OTHERWISE NOTED.
- SCHEDULE ALL DISCONNECTION AND INTERRUPTIONS OF ELECTRICAL SERVICE, COMMUNICATIONS AND SUPERVISORY SYSTEMS WITH THE OWNER AND ENGINEER.
- CONTRACTORS SHALL FOLLOW ALL OWNER SITE SAFETY WORK PROCESSES AND PROCEDURES. FOR EXAMPLE, WORK PERMITS, SAFETY TASK ANALYSES, LOCKOUT TAGOUT (LOTO), LOCK, TAG AND TRY, AND RED TAG, ETC.
- CONTRACTORS SHALL COORDINATE ALL WORK ACTIVITIES WITH OPERATIONS, MAINTENANCE, AND OTHER CONTRACTORS.
- UNLESS SPECIFICALLY NOTED, ALL ELECTRICAL EQUIPMENT (GENERATORS, AUTOMATIC TRANSFER SWITCHES, PANELBOARDS, MOTOR CONTROLLERS, WIRE, PANELBOARDS, SWITCHBOARDS, DISCONNECTS, LIGHTING, INSTRUMENTS, CONTROL PANELS, MOTOR, ETC.) THAT MAY BE SHOWN AS TO BE REMOVED ARE THE PROPERTY OF THE OWNER AND SHALL BE RETURNED TO THE OWNER.

ABBREVIATIONS

A OR AMP	AMPERES	PVC	POLYVINYLCHLORIDE CONDUIT
ACT	ABOVE COUNTER TOP (6")	PWR	POWER
AF	AMP FRAME	R&R	REMOVE AND RELOCATE
AFF	ABOVE FINISHED FLOOR	R	RELOCATE
AHU	AIR HANDLING UNIT	RE	RELOCATED
AIC	AMPERE INTERRUPTING CAPACITY	RECEPT	RECEPTACLE
AM	AMMETER	REF	REFERENCE
AMMETER	AMMETER SELECTION SWITCH	RGS	RIGID GALVANIZED STEEL
APPROX	APPROXIMATELY	RMS	ROOT MEAN SQUARE
AS	ASYMMETRICAL	SE	SERVICE ENTRANCE
ASYM	AMP TRIP	SF	SEAL FITTING
AT	AUTOMATIC TRANSFER CONTROLLER	SH	SHIELDED
ATC	AUTOMATIC TRANSFER SWITCH	SS	STAINLESS STEEL
ATS	AUXILIARY	SPD	SURGE PROTECTION DEVICE
AUX	AMERICAN WIRE GAUGE	SW	SWITCH
AWG	BARE COPPER	SWBD	SWITCHBOARD
BC	BUILDING	SYM	SYMMETRICAL
BLDG	CONDUIT	TEL	TELEPHONE
C	CONDUIT	TWIS	TWISTED INDIVIDUAL SHIELD
C, CDT	CONDUCTOR	TWOS	TWISTED OUTER SHIELD
C, /C	CIRCUIT BREAKER	TYP	TYPICAL
CB	CIRCUIT	UG	UNDERGROUND
CKT	CIRCUIT	UL	UNDERWRITER'S LABORATORIES
CLF	CURRENT LIMITING FUSE	UV	ULTRAVIOLET
CO	COMPANY	V	VOLTS
COL	COLUMN	VA	VOLT AMPS
CNTL	CONTROL	VAC	VOLTS ALTERNATING CURRENT
CSLD	CONTINUOUS STATISTICAL LEAK DETECTION	VDC	VOLTS DIRECT CURRENT
CT	CURRENT TRANSFORMER	VFD	VARIABLE FREQUENCY DRIVE
Cu	CABLE	VM	VOLTMETER
D	DEPTH	VMS	VOLTMETER SELECTOR SWITCH
DIA	DIAMETER	W	WATT
DS OR DISC	DISCONNECT SWITCH	W/	WITH
DWG(S)	DRAWING(S)	W/O	WITHOUT
ELEC	ELECTRIC, ELECTRICAL	WM	WATTMETER
EM	EMERGENCY	WP	WEATHER PROOF
EMT	ELECTRICAL METALLIC TUBING	XFMR	TRANSFORMER
ESTOP	EMERGENCY STOP		
EX, EXIST.	EXISTING		
EXP	EXPLOSION PROOF		
EF	EXHAUST FAN		
EG	EQUIPMENT GROUND		
EGC	EQUIPMENT GROUND CONDUCTOR		
ETC	ET CETERA		
EXIST	EXISTING		
F	FUSE		
FCR	FLOAT CONTROL RELAY		
FL, FLR	FLOOR		
FT	FEET		
G OR GND	GROUND		
GA	GAUGE		
GALV	GALVANIZED		
GEC	GROUNDING ELECTRODE CONDUCTOR		
GEN	GENERATOR		
GF	GROUND FAULT		
GFCI	GROUND FAULT CIRCUIT INTERRUPT		
GFI	GROUND FAULT INTERRUPTING		
H-O-A	HAND-OFF-AUTOMATIC		
HP	HORSEPOWER		
HVAC	HEATING, VENTILATION & AIR		
IG	ISOLATED GROUND		
ISBR	INTRINSICALLY SAFE BARRIER RELAY		
IMC	INTERMEDIATE METAL CONDUIT		
IN	INCH		
IR	INFRARED		
ISCA	INSTANTANEOUS SHORT CIRCUIT AVAILABLE		
JB OR J	JUNCTION BOX		
kVA	KILOVOLT - AMPS		
kW	KILOWATTS		
kWH	KILOWATT-HOUR		
L	LENGTH		
LA	LIGHTNING ARRESTOR		
LFMC	LIQUIDTIGHT FLEXIBLE METAL CONDUIT		
LTG	LIGHTING		
MAX	MAXIMUM		
MCB OR MB	MAIN CIRCUIT BREAKER		
MCC	MOTOR CONTROL CENTER		
MECH	MECHANICAL		
MER	MECHANICAL EQUIPMENT ROOM		
MFR	MANUFACTURER		
MH OR MTG	MOUNTING HEIGHT		
MIN	MINIMUM		
MLO	MAIN LUGS ONLY		
MTD	MOUNTED		
N	NEUTRAL		
NC	NORMALLY CLOSED		
NEC	NATIONAL ELECTRICAL CODE		
NEMA	NATIONAL ELECTRICAL MFRS ASSOCIATION		
NF	NON-FUSIBLE		
NFPA	NATIONAL FIRE PROTECTION ASSOCIATION		
No.	NUMBER		
NO	NORMALLY OPEN		
NTS	NOT TO SCALE		
O.C.	ON CENTER		
OCPD	OVERCURRENT PROTECTIVE DEVICE		
O/F	OVERFILL		
OHE	OVERHEAD ELECTRICAL		
OSHA	OCCUPATIONAL SAFETY & HEALTH ADMINISTRATION		
P	POLE		
PERM	PERMANENT		
PFC	POWER FACTOR CAPACITOR		
PH, Ø	PHASE		
PLC	PROGRAMMABLE LOGIC CONTROLLER		
PNL	PANEL		
PR	PAIR		

ABBREVIATIONS

PVC	POLYVINYLCHLORIDE CONDUIT
PWR	POWER
R&R	REMOVE AND RELOCATE
R	RELOCATE
RE	RELOCATED
RECEPT	RECEPTACLE
REF	REFERENCE
RGS	RIGID GALVANIZED STEEL
RMS	ROOT MEAN SQUARE
SE	SERVICE ENTRANCE
SF	SEAL FITTING
SH	SHIELDED
SS	STAINLESS STEEL
SPD	SURGE PROTECTION DEVICE
SW	SWITCH
SWBD	SWITCHBOARD
SYM	SYMMETRICAL
TEL	TELEPHONE
TWIS	TWISTED INDIVIDUAL SHIELD
TWOS	TWISTED OUTER SHIELD
TYP	TYPICAL
UG	UNDERGROUND
UL	UNDERWRITER'S LABORATORIES
UV	ULTRAVIOLET
V	VOLTS
VA	VOLT AMPS
VAC	VOLTS ALTERNATING CURRENT
VDC	VOLTS DIRECT CURRENT
VFD	VARIABLE FREQUENCY DRIVE
VM	VOLTMETER
VMS	VOLTMETER SELECTOR SWITCH
W	WATT
W/	WITH
W/O	WITHOUT
WM	WATTMETER
WP	WEATHER PROOF
XFMR	TRANSFORMER

ONE-LINE DIAGRAM

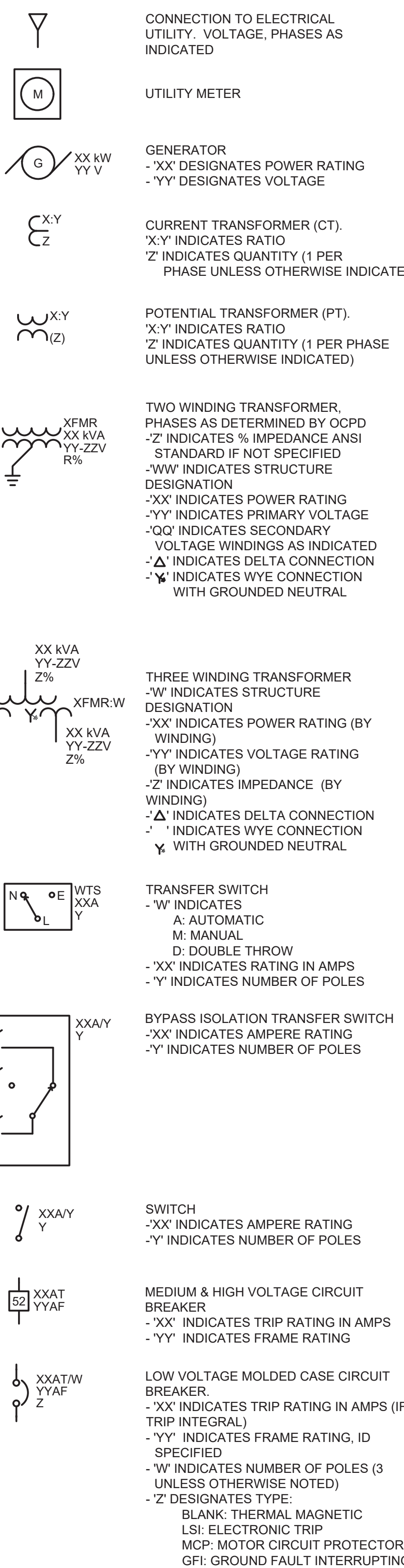

ONE-LINE DIAGRAM

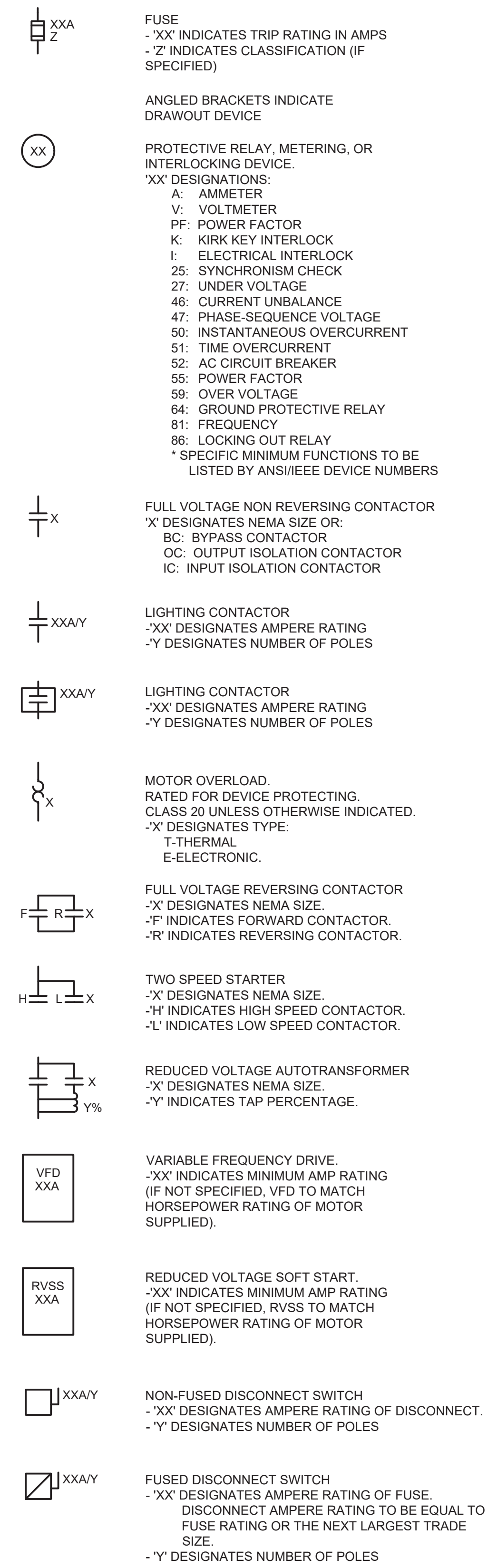

ONE-LINE DIAGRAM

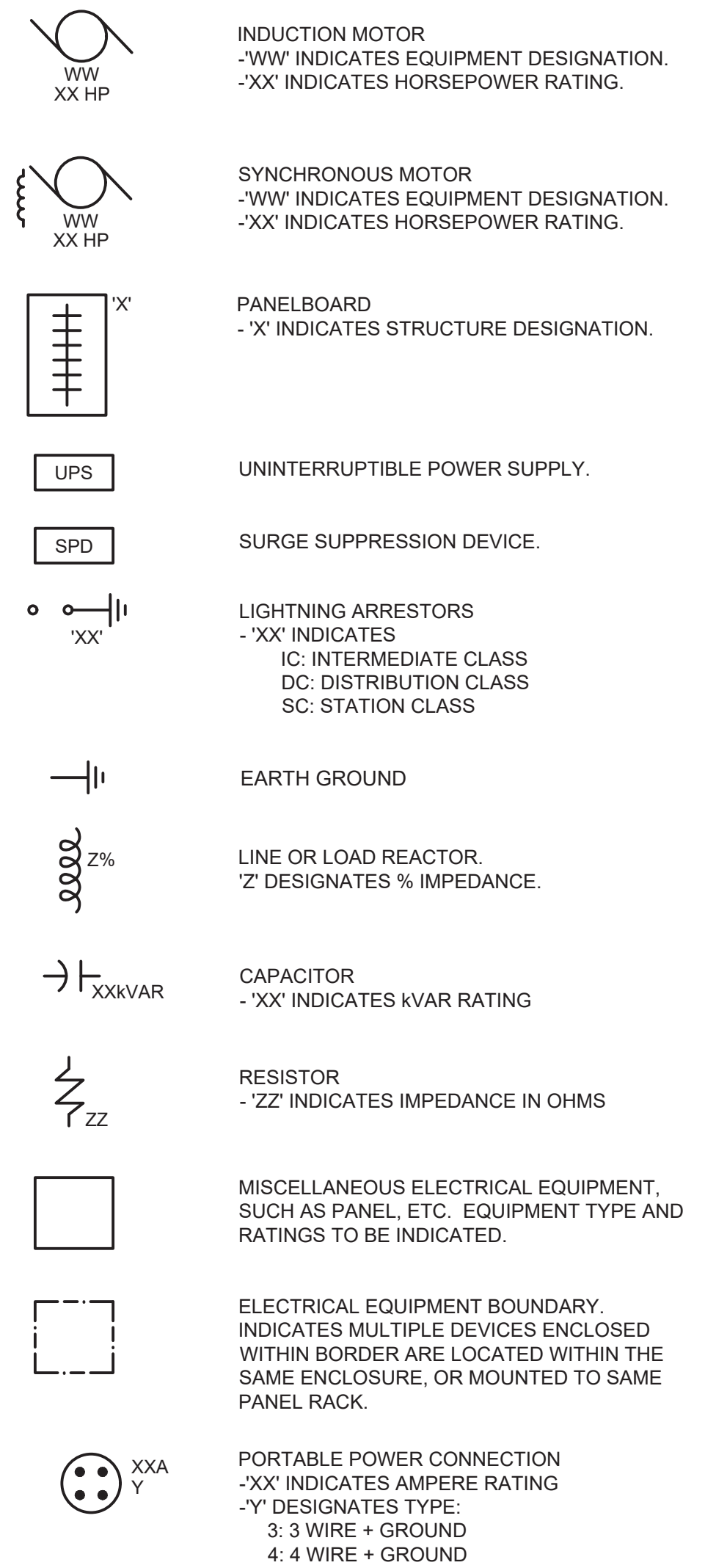

ANSI D (34-227)

MOTT MACDONALD
930 Main Campus Drive,
Suite 200
Raleigh, NC 27606
License No. F-0669
T +1 (919) 552 2254
F +1 (919) 552 2254
www.mottmacamericas.com

GRAPHIC SCALE

Digitally signed by Andrew K Gibbs
Date: 2026.02.17 08:02:04-06'00'

PROJECT ENGINEER

ANDREW K. GIBBS, P.E.
NC LICENSE: 041677

Designed By	RICHARD FERREIRA	County	DARE COUNTY
Entered By	RICHARD FERREIRA	Division	FERRY DIVISION
Project Engineer	ANDREW GIBBS	Plan Date	1-14-2026
Project Manager	ALLISON THORBURN		
Rev.	Date	Drawn	Description
			Ch'k'd
			App'd

NCDOT PASSENGER FERRY DOCK REPLACEMENT - HATTERAS ISLAND

E-001
ELECTRICAL LEGEND AND NOTES 1

SHEET 21 OF 26

LIGHTING

	CEILING MOUNTED FIXTURE. 'XX' DESIGNATES FIXTURE TYPE AS SPECIFIED ON LIGHTING FIXTURE SCHEDULE.
	FIXTURE PROVIDING EMERGENCY ILLUMINATION. 'XX' DESIGNATES FIXTURE TYPE AS SPECIFIED ON LIGHTING FIXTURE SCHEDULE.
	CEILING MOUNTED DOWNLIGHTING FIXTURE. 'XX' DESIGNATES FIXTURE TYPE AS SPECIFIED ON LIGHTING FIXTURE SCHEDULE.
	SURFACE MOUNT OR SUSPENDED FIXTURE INDUSTRIAL STRIP TYPE FIXTURE. 'XX' DESIGNATES FIXTURE TYPE AS SPECIFIED ON LIGHTING FIXTURE SCHEDULE.
	WALL MOUNTED FIXTURE. 'XX' DESIGNATES FIXTURE TYPE AS SPECIFIED ON LIGHTING FIXTURE SCHEDULE.
	TRACK LIGHTING. LENGTH AND NUMBER OF FIXTURES AS INDICATED ON PLANS. 'XX' DESIGNATES FIXTURE TYPE AS SPECIFIED ON LIGHTING FIXTURE SCHEDULE.
	TWIN HEAD EMERGENCY BATTERY UNIT. 'XX' DESIGNATES FIXTURE TYPE AS SPECIFIED ON LIGHTING FIXTURE SCHEDULE.
	CEILING MOUNTED REMOTE BATTERY HEADS. AIMING AS INDICATED. 'XX' DESIGNATES FIXTURE TYPE AS SPECIFIED ON LIGHTING FIXTURE SCHEDULE.
	WALL MOUNTED REMOTE BATTERY HEADS. AIMING AS INDICATED. 'XX' DESIGNATES FIXTURE TYPE AS SPECIFIED ON LIGHTING FIXTURE SCHEDULE.
	EXIT SIGN; CEILING MOUNTED; ARROWS AS INDICATED. 'XX' DESIGNATES FIXTURE TYPE AS SPECIFIED ON LIGHTING FIXTURE SCHEDULE.
	EXIT SIGN; WALL MOUNTED; ARROWS AS INDICATED. 'XX' DESIGNATES FIXTURE TYPE AS SPECIFIED ON LIGHTING FIXTURE SCHEDULE.
	EXIT SIGN WITH EMERGENCY HEADS; ARROWS AS INDICATED. 'XX' DESIGNATES FIXTURE TYPE AS SPECIFIED ON LIGHTING FIXTURE SCHEDULE.
	POLE MOUNTED LIGHT FIXTURE. 'XX' DESIGNATES FIXTURE TYPE AS SPECIFIED ON LIGHTING FIXTURE SCHEDULE. ONLY SINGLE FIXTURE SHOWN.
	WALL SWITCH. 'XX' DESIGNATES: NO SUBSCRIPT DENOTES SINGLE POLE 3 - 3 WAY SWITCH 4 - 4 WAY SWITCH D - DIMMER K - KEY OPERATED L - WITH PILOT LIGHT M - MOTOR RATED O - OCCUPANCY MOTION SENSOR W/OVERRIDE T - TIMER AS - DENOTES OCCUPANCY OVERRIDE CR - CORROSION RESISTANT EP - EXPLOSION PROOF TS - TIME SWITCH WP - WEATHERPROOF
	LIGHTING CONTROL POWER PACK
	CEILING MOUNTED SENSOR. 'X' DESIGNATES SENSOR AS SPECIFIED IN THE SENSOR SCHEDULE.
	WALL MOUNTED OCCUPANCY SENSOR. 'X' DESIGNATES SENSOR AS SPECIFIED IN THE SENSOR SCHEDULE.

ALL DEVICES/PLATES TO BE IN OWNERS CHOICE OF COLORS.

RACEWAYS

	OVERHEAD ELECTRICAL
	CONDUIT RUN CONCEALED ABOVE CEILING OR IN WALLS
	CONDUIT RUN BELOW GRADE OR IN SLAB
	CONDUIT RUN EXPOSED PARALLEL OR PERPENDICULAR TO BUILDING LINES
	HOMERUN TO PANELBOARD ANY CIRCUIT WITHOUT FURTHER DESIGNATION 2#12, 1#12 GRD. MINIMUM CONDUIT SIZE SHALL BE 3/4"
	FLEXIBLE CONDUIT
	CONDUIT TURNING DOWN
	CONDUIT TURNING UP
	CONDUIT CAPPED
	EXPLOSIONPROOF CONDUIT SEAL
	CONDUIT EXPANSION FITTING
	HAND HOLE (SIZE PER NEC)
	MAN HOLE (SIZE PER NEC)
	PULL BOX (DRAWN TO SCALE ON PLANS)
	CABLE TRAY (DRAWN TO SCALE ON PLANS)
	CONCRETE ENCASED DUCT BANK BELOW GRADE
	CABLE TAG. DESIGNATIONS: FOR 'W': H - POWER (>5KVAC) M - POWER (601-4999VAC) P - POWER (241-600VAC) L - POWER (51-240VAC) D - DC POWER C - CONTROL (TO A STARTER) I - INSTRUMENTATION (TO A PLC) E - EMERGENCY SHUT DOWN F - FIBER OPTIC COMMUNICATIONS O - OTHER COMMUNICATIONS FOR 'XXXX': EQUIPMENT REFERENCE FOR 'YY': ALPHANUMERIC SUFFIX AS NEEDED
	RACEWAY TAG. DESIGNATIONS: FOR 'XXX': ELECTRICAL SHEET REFERENCE FOR 'YY': SEQUENTIAL REFERENCE

GROUNDING & LIGHTNING PROTECTION

	GROUND ROD.
	GROUND TEST STATION.
	GROUND ANODE.
	VEHICLE GROUNDING STATION.
	GROUNDING GRID OR COUNTERPOISE SYSTEM CONDUCTOR.
	LIGHTNING PROTECTION AIR TERMINAL.
	LIGHTNING PROTECTION DISSIPATION AIR TERMINAL.
	LIGHTNING PROTECTION SYSTEM CONDUCTOR.
	LIGHTNING PROTECTION SYSTEM DOWN CONDUCTOR.

ELEMENTARY WIRING SCHEMATICS

	PRESSURE SWITCH - NORMALLY OPEN.
	PRESSURE SWITCH - NORMALLY CLOSED.
	DIFFERENTIAL PRESSURE SWITCH - NORMALLY OPEN.
	DIFFERENTIAL PRESSURE SWITCH - NORMALLY CLOSED.
	TIME DELAY SWITCH - TIMER ON DELAY (CLOSES AFTER TIMER EXPIRES).
	TIMER DELAY SWITCH - TIMER OFF DELAY (OPENS AFTER TIMER EXPIRES).
	VIBRATION SWITCH - NORMALLY OPEN
	VIBRATION SWITCH - NORMALLY CLOSED
	PANEL MOUNTED INDICATOR LIGHT 'X' INDICATES COLOR: A - AMBER G - GREEN R - RED W - WHITE B - BLUE
	PANEL MOUNTED INDICATOR LIGHT 'PUSH TO TEST' TYPE. 'X' INDICATES COLOR: A - AMBER G - GREEN R - RED W - WHITE B - BLUE
	EXTERNALLY MOUNTED DEVICE. DASHED LINE INDICATES WIRING EXTERNAL TO PANEL.
	TERMINAL BLOCK. 'X' INDICATES TERMINAL NUMBER. '#B' INDICATES TERMINAL BLOCK NUMBER
	PHOTOCELL.
	SELECTOR SWITCH. 'X' INDICATES SWITCH POSITION. TOTAL DIGITS PER LINE INDICATES NUMBER OF SWITCH POSITIONS (THREE SHOWN).
	MOMENTARY PUSH BUTTON - NORMALLY OPEN
	MOMENTARY PUSH BUTTON - NORMALLY CLOSED
	EMERGENCY SHUTDOWN/STOP - NORMALLY CLOSED
	COIL CONTACTS. VOLTAGE AS INDICATED ON SCHEMATICS 'X' DESIGNATES: C - CONTROL RELAY LC - LIGHTING CONTACTOR M - MOTOR CONTACTOR T - TIME DELAY RELAY
	SOLENOID COIL.
	NORMALLY OPEN CONTACT.
	NORMALLY CLOSED CONTACT.
	LIMIT SWITCH - NORMALLY OPEN.
	LIMIT SWITCH - NORMALLY CLOSED.
	LIMIT SWITCH - NORMALLY OPEN, HELD CLOSED.
	LIMIT SWITCH - NORMALLY CLOSED, HELD OPEN.
	LIQUID LEVEL (FLOAT) SWITCH - NORMALLY OPEN.
	LIQUID LEVEL (FLOAT) SWITCH - NORMALLY CLOSED.
	FLOW SWITCH - NORMALLY OPEN.
	FLOW SWITCH - NORMALLY CLOSED.
	TEMPERATURE SWITCH - NORMALLY OPEN.

OUTLETS AND RECEPTACLES

	DUPLEX RECEPTACLE, MOUNT 18" AFF UNLESS OTHERWISE NOTED.
	QUADPLEX RECEPTACLE, MOUNT 18" AFF UNLESS OTHERWISE NOTED.
	SINGLE OUTLET RECEPTACLE, MOUNT 18" AFF UNLESS OTHERWISE NOTED.
	SPECIAL PURPOSE RECEPTACLE, MOUNT 18" AFF UNLESS OTHERWISE NOTED.
FOR ALL RECEPTACLES, 'XX' DESIGNATES: AC - INSTALL 6" ABOVE COUNTER / BACKSPLASH (GFI REQUIRED). CLG - CEILING MOUNT CR - CORROSION RESISTANT EP - EXPLOSION PROOF GF - GROUND FAULT WP - WEATHERPROOF	
	MULTI-RECEPTACLE ASSEMBLY WITH RECEPTACLES AS INDICATED.
	JUNCTION BOX
	FLOOR MOUNTED DUPLEX RECEPTACLE.
	FLOOR MOUNTED BOX POWER AND TELCOM RECEPTACLES.
ALL DEVICES/PLATES TO BE IN OWNERS CHOICE OF COLORS.	

COMMUNICATIONS

	WALL MOUNTED DATA OUTLET. 18" AFF UNLESS OTHERWISE NOTED.
	FLOOR MOUNTED DATA OUTLET. 'X' DESIGNATES: F - FLUSH S - SURFACE
	WALL MOUNTED TELEPHONE OUTLET. 18" AFF UNLESS OTHERWISE NOTED.
	FLOOR MOUNTED TELEPHONE OUTLET. 'X' DESIGNATES: F - FLUSH S - SURFACE
	WALL MOUNTED TELEPHONE/DATA COMBINATION OUTLET. 18" AFF UNLESS OTHERWISE NOTED.
	FLOOR MOUNTED TELEPHONE/DATA COMBINATION OUTLET. 'X' DESIGNATES: F - FLUSH S - SURFACE
	BLUE INDICATOR LIGHT FOR EMERGENCY CALL BOX.
	EMERGENCY CALL BOX.
	LANE USE SIGNAL. 18" X 18" LED TYPE WITH GREEN "1" AND RED "X".
	CCTV CAMERA. MOUNTING AS INDICATED ON PLANS. 'X' DESIGNATES: F - FIXED TYPE PTZ - PAN TILT ZOOM
	ETHERNET ADAPTER
	CELLULAR MODEM
HVAC	
	THERMOSTAT
	AMBIENT TEMPERATURE TRANSMITTER
	UNIT HEATER

ELEMENTARY WIRING SCHEMATICS

	KEY SWITCH
	NON RESETTABLE RUN TIME METER.
	BATTERY - VOLUME AND AMP HOURS AS INDICATED.
	FULL WAVE RECTIFIER.
	HORN ELEMENT.
	EXTERNALLY MOUNTED ALARM LIGHT.

FIRE ALARM

	VOICE EVACUATION PANEL
	FIRE ALARM ANNUNCIATOR PANEL
	FIRE ALARM CONTROL PANEL
	FIRE ALARM MANUAL PULL STATION
	FIRE ALARM SMOKE DETECTOR
	HEAT DETECTOR
	FIRE ALARM DUCT SMOKE DETECTOR
	FIRE ALARM STROBE LIGHT WALL MOUNTED
	FIRE ALARM SPEAKER/STROBE LIGHT COMBINATION WALL MOUNTED
	HORN UNIT ONLY
	FIRE ALARM STROBE CEILING MOUNTED
	FIRE ALARM RELAY
	FIRE EXTINGUISHER.
	FIRE ALARM FLOW SWITCH
	LOW PRESSURE SWITCH
	FIRE ALARM TAMPER SWITCH
	FIRE ALARM TELEPHONE BASE
	MASS NOTIFICATION SPEAKER/STROBE LIGHT COMBINATION (WEATHER PROOF) WALL MOUNTED
	MASS NOTIFICATION SPEAKER/STROBE LIGHT COMBINATION (WEATHER PROOF) CEILING MOUNTED
	MASS NOTIFICATION SPEAKER CEILING MOUNTED

MOTT MACDONALD
 930 Main Campus Drive,
 Suite 200
 Raleigh, NC 27606
 License No. F-0669
 T +1 (919) 552 2253
 F +1 (919) 552 2254
 www.mottmacamericas.com

GRAPHIC SCALE

PROJECT ENGINEER
 ANDREW K. GIBBS, P.E.
 NC LICENSE: 041677

Designed By	RICHARD FERREIRA	County	DARE COUNTY
Entered By	RICHARD FERREIRA	Division	FERRY DIVISION
Project Engineer	ANDREW GIBBS	Plan Date	1-14-2026
Project Manager	ALLISON THORBURN		
Rev.	Date	Drawn	Description

NCDOT PASSENGER FERRY DOCK REPLACEMENT - HATTERAS ISLAND

E-002
 ELECTRICAL LEGEND AND NOTES 2

KEY NOTES

- A. RECEPTACLES SHALL BE:
WP-WEATHERPROOF
CR-CORROSION RESISTANT
GF-GROUND FAULT.
- B. SEE PLANS FOR CONDUIT ROUTING.

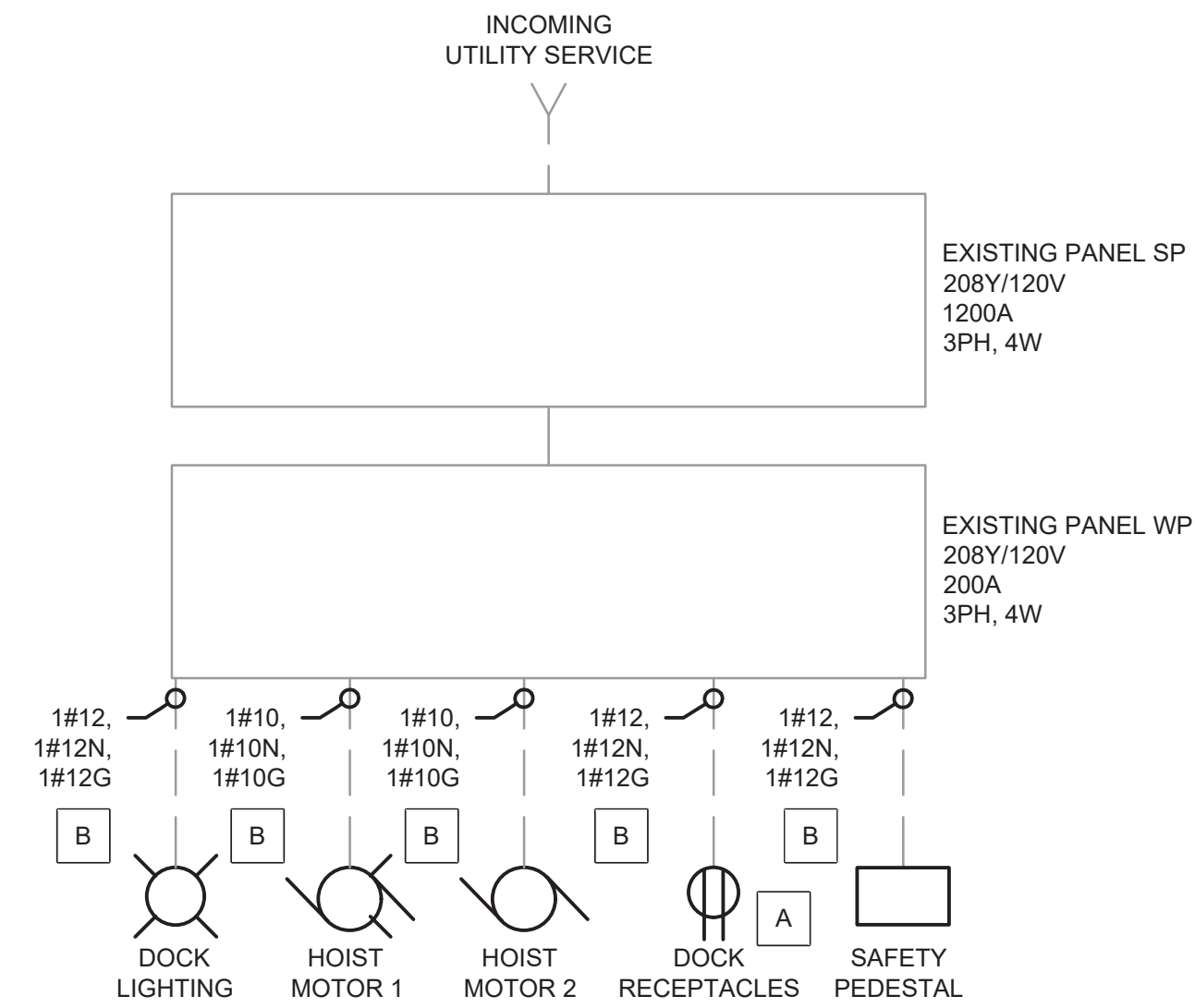

ONE-LINE DIAGRAM
NO SCALE

LIGHTING FIXTURE SCHEDULE									
MARK	MANUFACTURER	CATALOG NUMBER	LAMPS-NUMBER/TYPE	FIXTURE WATTS	LUMEN OUTPUT	TOTAL LLF	CCT	MOUNTING	REMARKS
P1	LITHONIA LIGHTING	DSX0 LED P1 AMLW AMCRI AFR	LED	27.42	1359	0.8	2,700K	POLE	15' MH
NOTES									
1. THE FIXTURES LISTED ABOVE ARE THE BASIS OF DESIGN. TO SUPPLY EQUIVALENT FIXTURES PROVIDE THE FOLLOWING WITH BID DOCUMENTS: 1) COMPLETE PRODUCT SPECIFICATION SHEETS MARKED WITH CATALOG NUMBER AND FIXTURE TYPE, 2) CALCULATION REPORTS SHOWING THE DESIGN CRITERIA HAS BEEN MET, 3) A SUMMARY OF ALL ALTERATIONS DEVIATING FROM THE BASIS OF DESIGN, 4) ELECTRONIC COPIES OF THE IES FILES USED, 5) WRITTEN VERIFICATION THAT THE SUBMITTED FIXTURES MEET THE REQUIREMENTS OF THE CONTRACT DOCUMENTS. EQUIVALENT FIXTURES SHALL BE VERIFIED BY THE ENGINEER FOR ADEQUACY DURING THE BID REVIEW PHASE. THE CONTRACTOR SHALL STILL BEAR THE RESPONSIBILITY OF PROVIDING AND INSTALLING FIXTURES THAT MEET THE DESIGN CRITERIA AND THE QUALITY OF THE BASIS OF DESIGN PRODUCTS, AT NO ADDITIONAL COST.									

LIGHTING DESIGN CRITERIA								
APPLICATION	HORIZONTAL TARGETS			VERTICAL TARGETS			UNIFORMITY TARGETS	
	E (fc)	TYPE	ELEV.	E (fc)	TYPE	ELEV.	MAX:MIN	AVG:MIN
HATTERAS DOCK	0.5	AVG	FLOOR	N/A	N/A	N/A	4:1	10:1
1. DESIGN CRITERIA ARE BASED ON THE UFC 3-530-01								

ANSI D (34-227)

M M
MOTT MACDONALD
930 Main Campus Drive,
Suite 200
Raleigh, NC 27606
License No. F-0669
T +1 (919) 552 2253
F +1 (919) 552 2254
www.mottmacamericas.com

GRAPHIC SCALE

Digitally signed by Andrew K. Gibbs
Date: 2026.02.17 08:02:06-06'00'
PROJECT ENGINEER
SEAL
041677
ANDREW K. GIBBS
ANDREW K. GIBBS, P.E.
NC LICENSE: 041677

Designed By	RICHARD FERREIRA	County	DARE COUNTY
Entered By	RICHARD FERREIRA	Division	FERRY DIVISION
Project Engineer	ANDREW GIBBS	Plan Date	1-14-2026
Project Manager	ALLISON THORBURN		
Rev.	Date	Drawn	Description

NCDOT PASSENGER FERRY DOCK REPLACEMENT - HATTERAS ISLAND

E-003
ELECTRICAL DIAGRAMS

PANEL: SP				LOCATION: HATTERAS DOCK			
OPTIONS							
VOLTS L-L:	208	MAIN OVERCURRENT:	1200A MCB	BUS MATERIAL:	Cu	MOUNTING:	SURFACE
VOLTS L-N:	120	MAIN BUS RATING:	1200A	NEUTRAL SIZE:	100%	ENCLOSURE TYPE:	NEMA 4X
PHASE:	3	MINIMUM A.I.C.:		GROUND:			SEPARATELY DERIVED
WIRE:	4						

CKT#	BKR.	POLE	TYPE	DESCRIPTION	VA	PHASE A	PHASE B	PHASE C	VA	DESCRIPTION	TYPE	POLE	BKR.	CKT#
1				SPACE		1921			1921	GATE OPERATOR/TOP RIGHT BREAKER		3	20 A	2
3				SPACE			1921		1921					4
5				SPACE				1921	1921					6
9				SPACE		0				SPACE				10
11				SPACE			0			SPACE				12
13				SPACE				0		SPACE				14
15				SPACE		1921			1921					16
17				SPACE			1921		1921	IQ BOX NORTH FUEL PUMPS		3	20 A	18
19				SPACE				1921	1921					20
21				SPACE	1921	1921				SPACE				22
23	20 A	3		IQ BOX SOUTH FUEL PUMPS	1921		1921			SPACE				24
25				SPACE	1921			1921		SPACE				26
27				SPACE	19214	21136			1921	LIGHT ON POLES		1	20 A	28
29	200 A	3		SHORE POWER #6	19214		21136		1921	PUMP CONTROLLER		1	20 A	30
31				SPACE	19214			21136	1921	DISPENSER		1	20 A	32
33				SPACE	19214	38428			19214					34
35	200 A	3		SHORE POWER #5 (CENTER RAMP)	19214		38428		19214	PUMP #2		3	200 A	36
37				SPACE	19214			38428	19214					38
39				SPACE	19214	38428			19214					40
41	200 A	3		SHORE POWER (SOUTH RAMP)	19214		38428		19214	PUMP #1		3	200 A	42
43				SPACE	19214			38428	19214					44
45				SPACE	24155	43369			19214					46
47	200 A	3		PANEL WP FEED	22179		41393		19214	SHORE POWER #2 & #4		3	200 A	48
49				SPACE	22355			41569	19214					50
51				SPACE	38428	57643			19214					52
53	400 A	3		OPERATIONS BUILDING PANEL BOARD	38428		57643		19214	SHORE POWER #7		3	200 A	54
55				SPACE	38428			57643	19214					56

TOTAL CONNECTED LOAD (VA) PER PHASE:	204769	202793	202969
CONNECTED LOAD (AMPS) PER PHASE:	1706	1690	1691

TOTAL CONNECTED LOAD (VA):	610530	NEC ARTICLE 220 LOAD (VA):	342049
AVERAGE CONNECTED LOAD (AMPS):	1695	AVERAGE ARTICLE LOAD (AMPS):	949

NOTES:	
1.	DEMAND LOAD CALCULATIONS BASED ON REMOVING REDUNANT LOADING AND RECEPTACLES VA.
2.	PROVIDE MANUFACTURER'S STANDARD SPD.
3.	PANEL SCHEDULES ARE BASED ON RECORD DRAWINGS PROVIDED. IT SHALL BE THE CONTRACTOR'S RESPONSIBILITY TO FIELD VERIFY CONNECTED LOADS PRIOR TO MODIFICATION OF PANELS.
4.	LOADS DEPICTED IN ITALICIZED FONT ARE REPRESENTATIVE OF EXISTING LOADS. LOADS DEPICTED IN BOLD FONT ARE REPRESENTATIVE OF NEW LOADS TO BE CONNECTED.

PANEL: WP				LOCATION: HATTERAS DOCK			
OPTIONS							
VOLTS L-L:	208	MAIN OVERCURRENT:	225A MCB	BUS MATERIAL:	Cu	MOUNTING:	SURFACE
VOLTS L-N:	120	MAIN BUS RATING:	225A	NEUTRAL SIZE:	100%	ENCLOSURE TYPE:	NEMA 4X
PHASE:	3	MINIMUM A.I.C.:		GROUND:			SEPARATELY DERIVED
WIRE:	4						

CKT#	BKR.	POLE	TYPE	DESCRIPTION	VA	PHASE A	PHASE B	PHASE C	VA	DESCRIPTION	TYPE	POLE	BKR.	CKT#
1				60 AMP SHORE POWER ON REC ON LEFT REC A	9607	11307			1700	HOIST MOTOR 1 (3/4HP)		1	20 A	2
3	100 A	3			9607		9607			SPACE		1		4
5					9607			9607		SPACE		1		6
7		1		SPACE		9607			9607	60 AMP SHORE POWER ON REC ON RIGHT REC B		3	100 A	8
9		1		SPACE			9607							10
11		1		SPACE				9607	9607					12
13	15 A	1		SEWER HOSE REEL	1440	1440				SPACE		1		14
15	20 A	1		RAIL LTS	84		84			SPACE		1		16
17		1		SPACE				0		SPACE		1		18
19		1		SPACE		1441			1441					20
21	15 A	1		WATER HOSE REEL	1440		2881		1441	FUEL HOSE REEL		3	15 A	22
23		1		SPACE				1441	1441					24
25		1		SPACE		360			360	DOCK RECEPTACLES		1	20 A	26
27		1		SPACE					20	SAFETY PEDESTAL		1	15A	28
29	20 A	1		HOIST MOTOR 2 (3/4HP)	1700			1700		SPACE		1		30

TOTAL CONNECTED LOAD (VA) PER PHASE:	24155	22199	22355
CONNECTED LOAD (AMPS) PER PHASE:	201	185	186

TOTAL CONNECTED LOAD (VA):	68710	NEC ARTICLE 220 LOAD (VA):	45815
AVERAGE CONNECTED LOAD (AMPS):	191	AVERAGE ARTICLE LOAD (AMPS):	127

NOTES:	
1.	DEMAND LOAD CALCULATIONS BASED ON REMOVING REDUNANT LOADING AND RECEPTACLES VA.
2.	PROVIDE MANUFACTURER'S STANDARD SPD.
3.	PANEL SCHEDULES ARE BASED ON RECORD DRAWINGS PROVIDED. IT SHALL BE THE CONTRACTOR'S RESPONSIBILITY TO FIELD VERIFY CONNECTED LOADS PRIOR TO MODIFICATION OF PANELS.
4.	LOADS DEPICTED IN ITALICIZED FONT ARE REPRESENTATIVE OF EXISTING LOADS. LOADS DEPICTED IN BOLD FONT ARE REPRESENTATIVE OF NEW LOADS TO BE CONNECTED.

ANSI D (34-227)

MOTT MACDONALD
 930 Main Campus Drive,
 Suite 200
 Raleigh, NC 27606
 License No. F-0669
 T +1 (919) 552 2253
 F +1 (919) 552 2254
 www.mottmacamericas.com

GRAPHIC SCALE

Digitally signed by Andrew K Gibbs
 Date: 2026.02.17 08:02:08-06'00'

ANDREW K. GIBBS, P.E.
 NC LICENSE: 041677

Designed By	RICHARD FERREIRA	County	DARE COUNTY
Entered By	RICHARD FERREIRA	Division	FERRY DIVISION
Project Engineer	ANDREW GIBBS	Plan Date	1-14-2026
Project Manager	ALLISON THORBURN		
Rev.	Date	Drawn	Description

SHEET 24 OF 26

NCDOT PASSENGER FERRY DOCK REPLACEMENT - HATTERAS ISLAND

E-004
 ELECTRICAL SCHEDULES

GENERAL NOTES

1. A SINGLE CIRCUIT WITH THE HIGHEST RATED CABLE SHALL CARRY GROUND. GROUND SHALL BE ESTABLISHED AND PULLED FROM CLOSEST JUNCTION BOX TO EACH PIECE OF EQUIPMENT RECEIVING POWER.

KEY NOTES

- A. ONE 1" CONDUIT, RECEPTACLES, SAFETY PEDESTAL, LIGHTS, AND MOTOR CIRCUITS SHALL BE COMBINED.
- B. 12"X12"X12" (INSIDE DIMENSIONS) ELECTRIC, HEAVY DUTY, GASKETED, AND ANSI TIER 15 HAND HOLE.
- C. 12"X12"X6" JUNCTION BOX, NEMA 4X, SS.

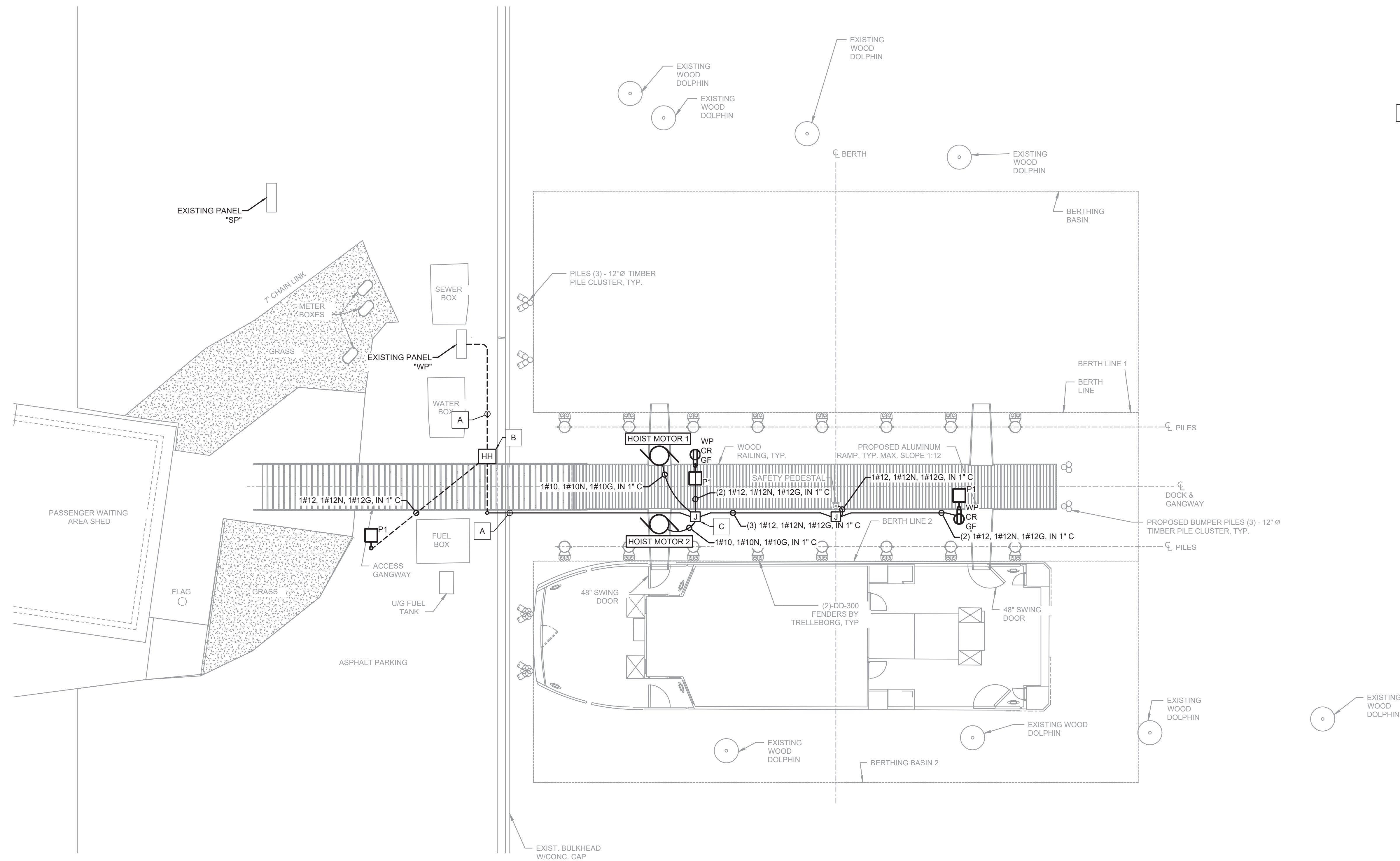

ELECTRICAL SITE PLAN
SCALE: 1"=20'-0"

Digitally signed by Andrew K Gibbs
Date: 2026.02.17 08:02:09-06'00'

M M
MOTT MACDONALD
930 Main Campus Drive,
Suite 200
Raleigh, NC 27606
License No. F-0669
T +1 (919) 552 2253
F +1 (919) 552 2254
www.mottmacamericas.com

GRAPHIC SCALE

GRAPHIC SCALE
20 10 0 20'
SCALE: 1" = 20'

PROJECT ENGINEER

SEAL
041677
ANDREW K. GIBBS
ANDREW K. GIBBS, P.E.
NC LICENSE: 041677

Designed By	RICHARD FERREIRA	County	DARE COUNTY
Entered By	RICHARD FERREIRA	Division	FERRY DIVISION
Project Engineer	ANDREW GIBBS	Plan Date	1-14-2026
Project Manager	ALLISON THORBURN		
Rev.	Date	Drawn	Description

NCDOT PASSENGER FERRY DOCK REPLACEMENT - HATTERAS ISLAND

E-100 ELECTRICAL SITE PLAN

ANSI D (94-227)

